

PIZZA OVEN (ELECTRICAL)

CONTENTS

A	GENERAL INFORMATION	Page 2
A1	PRODUCT DESCRIPTION	Page 3
A2	TECHNICAL INFORMATION	Page 3
A3	TRANSPORTATION	Page 4
A4	UNPACKING	Page 4
B	INSTALLATION	Page 4
C	SAFETY INSTRUCTIONS	Page 5
D	OPERATION	Page 6
E	CLEANING & MAINTENANCE.....	Page 8
F	TROUBLESHOOTING.....	Page 9
G	SPARE PART LIST- EXPLODING DRAWING	Page 10
H	ELECTRIC CIRCUIT SCHEMA	Page 20

A GENERAL INFORMATION

Before installing the appliance, read operation and maintenance instructions carefully. Wrong installation and part changing may damage the product or may cause injury on people. These are not in our company's responsibility to damage the appliance intentionally, negligence, detriments because of disobeying instructions and regulations, wrong connections. Unauthorized intervention to appliance invalidates the warranty.

1. This instruction manual should be kept in a safe place for future reference.
- 2. Installation should be made in accordance with ordinances and security rules of that country by a qualified service personnel.**
3. This appliance has to be used by trained person.
4. Please turn off the appliance immediately in the event of malfunction or failure. The appliance should be repaired only by authorized service personnel. Please demand original spare part.

PIZZA OVEN (ELECTRICAL)

A1 PRODUCT DESCRIPTION

*The Professional Pizza Ovens (Electric), that provides high efficiency has been designed to be used in industrial kitchen.

Product Code	Dimensions (mm)	Weight (kg)	Packaging Dimensions (mm)
EMP.4+4	825x710x670	95	930x820x820
EMP.5+5	890x810x760	120	1000x930x940
EMP.6+6	1190x810x760	152	1250x930x920
EMP.8+8	965x900x760	150	1025x820x930
EMP.9+9	1190x1110x760	208	1260x1220x930

A2 TECHNICAL INFORMATION

Product Code	Inneer Dimension	Capacity	Electric Inlet (V)	Cable (mm ²)	Power (KW)	Fuse (A)
EMP.4+4	525x525x145	Ø250 mm x 4+4 ad.pizza	400	5x2,5	10,9	3x 25
EMP.5+5	620x620x174	Ø300 mm x 5+5 ad.pizza	400	5x2,5	11,4	3x 25
EMP.6+6	920x620x174	Ø300 mm x 6+6 ad.pizza	400	5x2,5	15	3x 32
EMP.8+8	705x705x145	Ø330 mm x 8+8 ad.pizza	400	5x2,5	15	3x 32
EMP.9+9	920x920x174	Ø300 mm x 9+9 ad.pizza	400	5x4	30	3x 63

*The vapor generator can be connected according to demand. In this situation there must be clean water inlet and waste water outlet where the appliance is installed.

A3 TRANSPORTATION

*This appliance can not be moved by hand from area to area. It must be moved on pallet with forklift truck.

A4 UNPACKING

*Please unpack the package according to the security codes and ordinances of current country and get rid from the pack. Parts which contacts with food are produced by stainless steel. All plastic parts are marked by material's symbol.

*Please check that all the parts of appliance had come completely and if they are damaged or not during the shipping.

B INSTALLATION

*Please place the product to straight and sturdy ground, please take necessary steps against possibility of overturn.

*Technician who will serve for installation and service for the appliance must be professional on this subject and must have installation and service licenses by the company.

*Connection to Electric Power Supply must be done by authorized person.

*Please be sure that the voltage connected to appliance must be equal with the voltage which is on appliance's label.

 This appliance must be connected to an earthed outlet in accordance with safety rules and standards.









*Appliance's earthing must be connected to earthing line on panel which is nearest to electric installation.

*Connection to the main fuse and leak current fuse must be done in accordance with the current regulations.

*For easy cleaning and maintenance of the appliance, there must be at least 50 cm space at right and left side of the appliance. The appliance should be operated under the chimney hood.

PIZZA OVEN (ELECTRICAL)

C SAFETY INSTRUCTIONS

-  *Do not use the appliance in insufficient lighted place.
-  *Do not touch the moving attachments while the appliance operates.
-  *Do not install the appliance in the presence of flammable or explosive materials. The distance between oven surface and flammable material must be minimum 10 cm.
-  *Do not operate the appliance when the machine is empty.
-  *Do not load so less or more than appliance's capacity.
-  *Do not attempt to use the appliance without suitable protective equipments.
-  *Because of any reason if there is a fire or flame flare where the appliance is used, turn off all gas valves and electric contactor switch quickly and use fire extinguisher. Never use water to extinguish the fire.
-  *All the damages because of not having earthing connection will not be on warranty.

D OPERATION

*Control Panel;

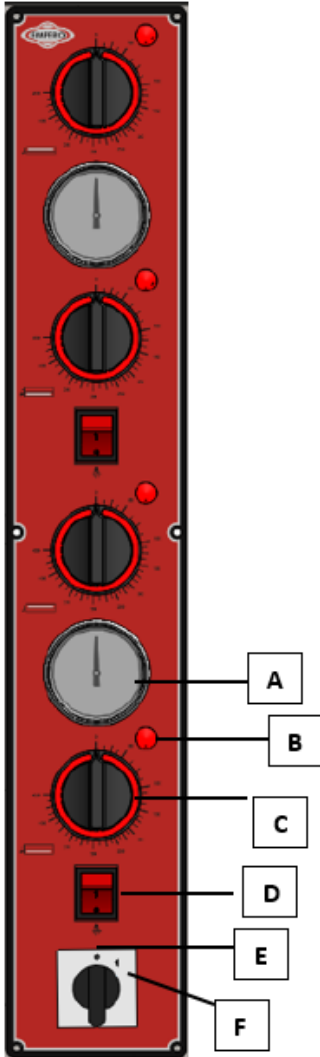

- A : Inner Temperature Indicator
- B : Thermostat Control Lamp
- C : Thermostat Button (0-400°C)
- D : Inner Lighting Button
- E : Switch OFF Position
- F : Switch ON Position



PIZZA OVEN (ELECTRICAL)

*Operating;

- Clean the inner and outer surface of the appliance with warm moist cloth and dry before the operation.
- Plug in the appliance and switch the thermostat to desired heat.
- There may be fog and smell due to isolation material and heater during first use. Therefore switch the thermostat to 400°C and operate it for 30 min when it is empty.
- Before inserting product to the appliance, preheat it. Operate the appliance over 60°C for 5-10 min.
- Adjust the upper and lower thermostats according to the chart at below due to products having different cooking time.
- In order to see the products without opening the lid during the cooking, press lighting button.
- When the operation is completed switch the thermostat to (0) position and unplug the appliance.

PRODUCT CODE	PIZZA	PITTA AND TURKISH PIZZA
EMP.4+4 EMP.5+5 EMP.6+6 EMP.8+8 EMP.9+9	1. ALTERNATIVE Lower Thermostat : 280°C Upper Thermostat : 300°C Cooking Time : 7-8 min 2. ALTERNATIVE Lower Thermostat : 300°C Upper Thermostat : 330°C Cooking Time : 5-6 min.	Lower Thermostat : 260°C Upper Thermostat : 280°C Cooking Time : 3-4 min

E CLEANING & MAINTENANCE

➤ **CLEANING AND MAINTENANCE AFTER EVERY USE**

- Always turn off the appliance and disconnect from the power supply before cleaning.
- Clean the inside of the oven with soft cloth by using oil solvent spray, before the appliance gets cooled exactly.
- Do not use abrasive cleaning chemicals as these can leave harmful residues.
- Do not clean the appliance by spraying water directly, otherwise electric motor may get damaged.
- Do not clean the appliance with the materials that may damage to chrome material.

➤ **PERIODIC CLEANING AND MAINTENANCE**

- Maintenance should be done by qualified person.
- Get the periodic maintenance of the appliance once in every 15 days.
- Check the lighting lamp according to frequency of use.
- Maintenance of the appliance's contactor should be done by compressed air according to frequency of use. (EMP.6+6 - EMP.9+9)

PIZZA OVEN (ELECTRICAL)

F TROUBLESHOOTING

THE APPLIANCE DOESN'T OPERATE	<ol style="list-style-type: none">1. Check if the appliance is plugged in.2. Check the electrical connections and voltage.3. Check if the fuse is on or off.4. Check the resistances.
--------------------------------------	--

THE APPLIANCE DOESN'T COOK WELL	<ol style="list-style-type: none">1. Check the heat settings.2. Do not overload the oven.
--	--

THE APPLIANCE STOPPED	<ol style="list-style-type: none">1. The appliance can stop due to low voltage. In this situation check the voltage.2. When the oven operating temperature is more than maximum temperature, the oven will get STOP position automatically.
------------------------------	--

<ul style="list-style-type: none">• If cooking at Pizza Ovens (Electric) is not done at suitable quality• If any function of security doesn't work<ul style="list-style-type: none">➤ Do not use the appliance.
--

***If these problems are still going on, contact with our authorized services.**

G SPARE PART LIST- EXPLODING DRAWINGS

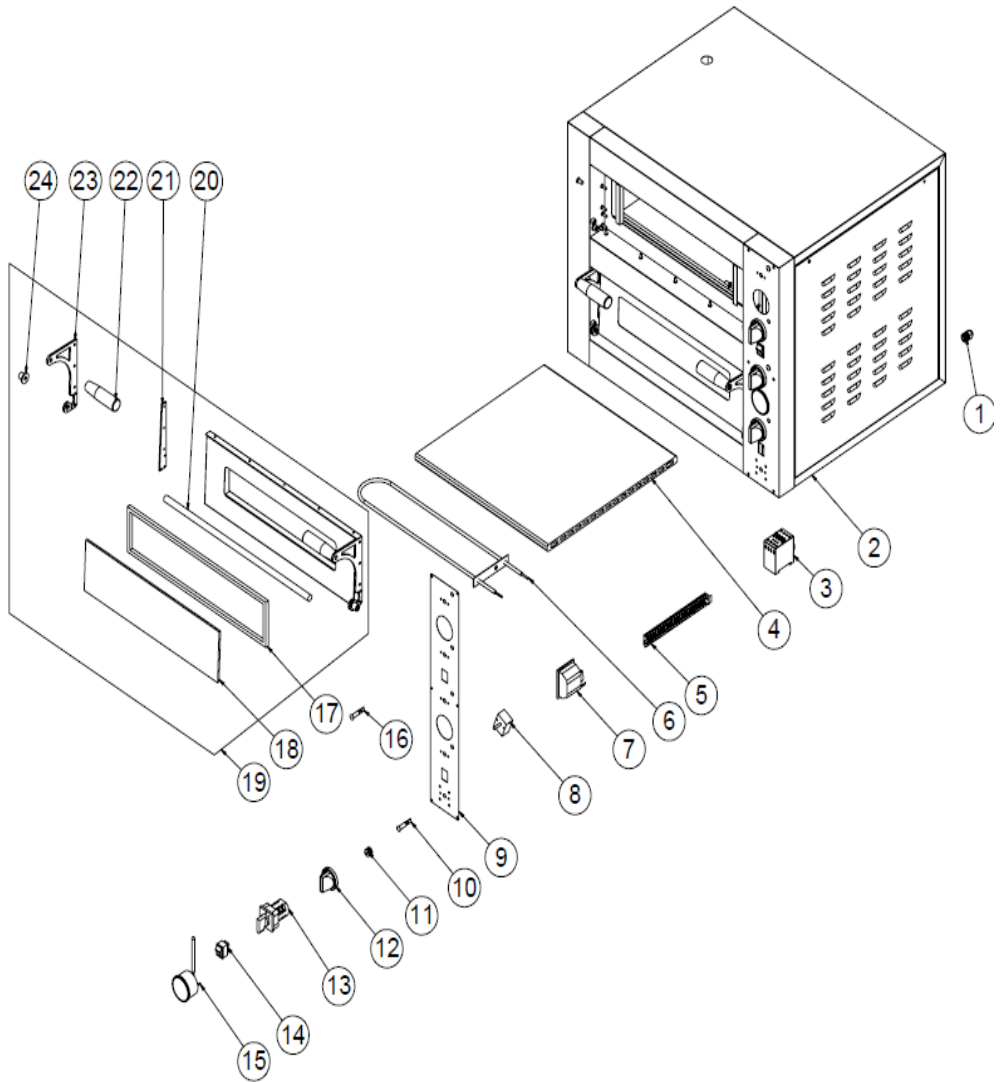

PIZZA OVEN (ELECTRICAL)

G SPARE PART LIST- EXPLODING DRAWINGS

PRODUCT CODE: EMP.4+4		
NO	PRODUCT NAME	P.CODE
1	PG-16 CABLE FITTING	JP.M.ELK-RKR-PLS-001
2	CHASSIS	-
3	LC1K0901M7 CONTACTOR	JP.M.ELK-KNT-KNT-020
4	515*507*18 MM PIZZA STONE	M.TAS-FRN-PC-002
5	COVER SHEET	YSC-KNX.EPZ-PN-0218
6	875W RESISTANCE	M.ELK-RZS-BRU-PZ4-001
7	LAMP	JP.M.ELK-LMB-AMP-002
8	85-450 °C THERMOSTAT	M.ELK-MEK-TRM1-002
9	TICKET	M.AKS-ETK-ALM-011
10	SIGNAL LAMP	M.ELK-LMB-SNY-002
11	BUTTON SOCKET	M.AKS-DGM-SKT-004
12	BUTTON	JP.M.AKS-DGM-MUH-
13	3LF0122-4AC00 0-1 3*20A SWITCH	JP.M.ELK-SLT-PKO-003
14	0-1 KEY	M.ELK-SLT-ANL-003
15	Ø 60 0-500 °C THERMOMETER	M.ELK-EDM-DGT-006
16	SIGNAL LAMP	M.ELK-LMB-SNY-007
17	GLASS WICK	HCN-ELY-KZ-001
18	520MM*140MM*6MM GLASS	M.CAM-TMP-018
19	COVER	ARA-KNX.EPZ-0002
20	LID WEIGHT SHAFT	YTL-KNX.EPZ-KS-0003
21	SUPPORT SHEET	YSC-KNX.EPZ-LZ-0043
22	M8 HANDLE	JP.M.AKS-KLP-BKL-002
23	COVER HANDLE	YSC-KNX.EPZ-LZ-0042
24	LID FITTING	YTL-KNX.GPZ-KS-0002

G SPARE PART LIST- EXPLODING DRAWINGS

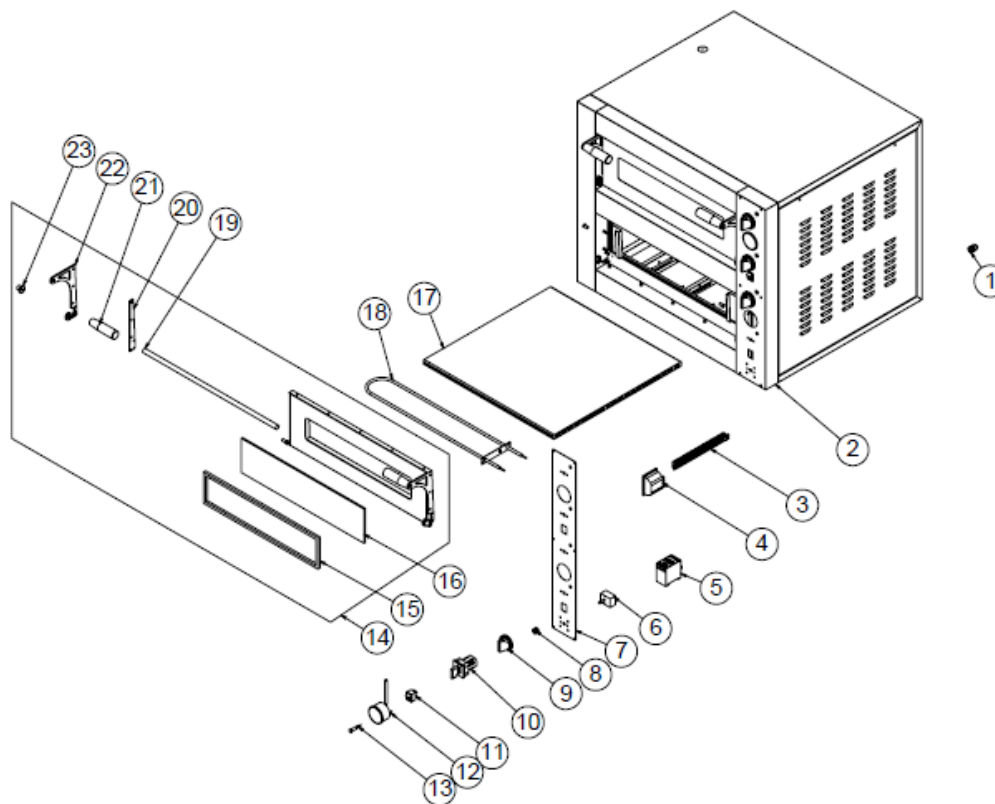

PIZZA OVEN (ELECTRICAL)

G SPARE PART LIST- EXPLODING DRAWINGS

PRODUCT CODE: EMP.5+5		
NO	PRODUCT NAME	P.CODE
1	PG-16 CABLE FITTING	JP.M.ELK-RKR-PLS-001
2	CHASSIS	-
3	COVER SHEET	YSC-KNX.EPZ-PN-0218
4	LAMP	JP.M.ELK-LMB-AMP-002
5	LC1K0901M7 CONTACTOR	JP.M.ELK-KNT-KNT-020
6	85-450 °C THERMOSTAT	M.ELK-MEK-TRM1-002
7	TICKET	M.AKS-ETK-ALM-013
8	BUTTON SOCKET	M.AKS-DGM-SKT-004
9	BUTTON	JP.M.AKS-DGM-MUH-005
10	3LF0122-4AC00 0-1 3*20A SWITCH	JP.M.ELK-SLT-PKO-003
11	0-1 KEY	M.ELK-SLT-ANL-003
12	Ø 60 0-500 °C THERMOMETER	M.ELK-EDM-DGT-006
13	SIGNAL LAMP	M.ELK-LMB-SNY-002
14	COVER	ARA-KNX.EPZ-0005
15	GLASS WICK	HCN-ELY-KZ-001
16	580MM*140MM*6MM GLASS	M.CAM-TMP-012
17	615*606*18 MM PIZZA STONE	M.TAS-FRN-PZ-001
18	940 W RESISTANCE	M.ELK-RZS-BRU-PZ5-002
19	LID WEIGHT SHAFT	YTL-KNX.EPZ-KS-0008
20	SUPPORT SHEET	YSC-KNX.EPZ-LZ-0045
21	M8 HANDLE	JP.M.AKS-KLP-BKL-002
22	COVER HANDLE	YSC-KNX.EPZ-LZ-0058
23	LID FITTING	YTL-KNX.GPZ-KS-0002

G SPARE PART LIST- EXPLODING DRAWINGS

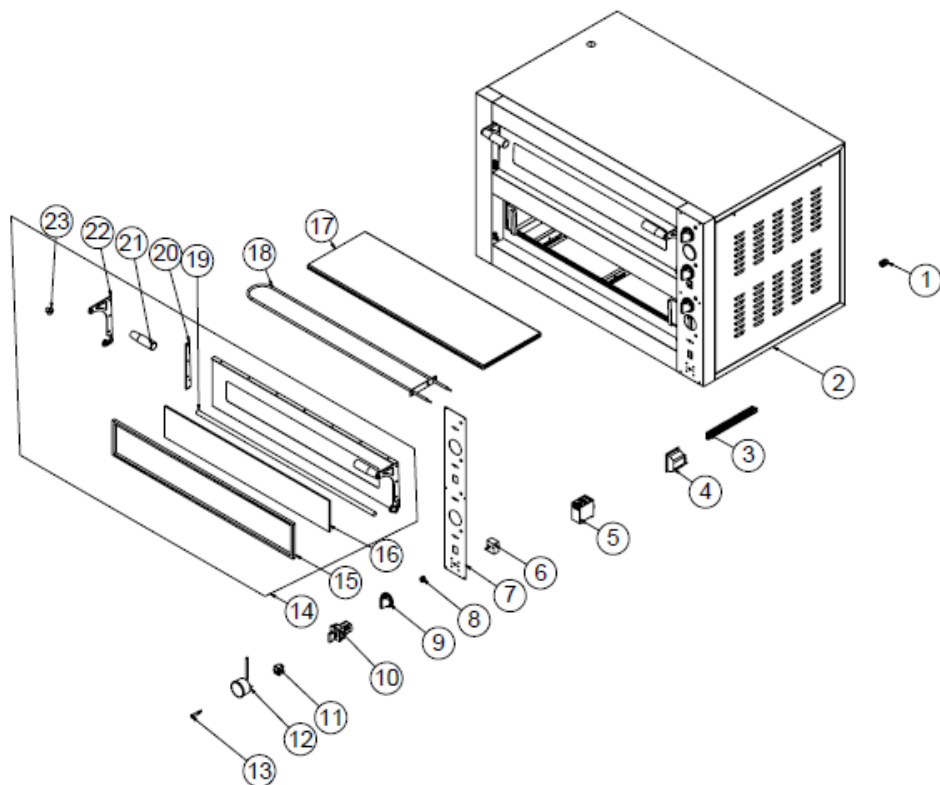

PIZZA OVEN (ELECTRICAL)

G SPARE PART LIST- EXPLODING DRAWINGS

PRODUCT CODE: EMP.6+6		
NO	PRODUCT NAME	P.CODE
1	PG-16 CABLE FITTING	JP.M.ELK-RKR-PLS-001
2	CHASSIS	-
3	COVER SHEET	YSC-KNX.EPZ-PN-0218
4	LAMP	JP.M.ELK-LMB-AMP-002
5	LC1K0901M7 CONTACTOR	JP.M.ELK-KNT-KNT-020
6	85-450 °C THERMOSTAT	M.ELK-MEK-TRM1-002
7	TICKET	M.AKS-ETK-ALM-013
8	BUTTON SOCKET	M.AKS-DGM-SKT-004
9	BUTTON	JP.M.AKS-DGM-MUH-005
10	3LF0122-4AC00 0-1 3*20A SWITCH	JP.M.ELK-SLT-PKO-003
11	0-1 KEY	M.ELK-SLT-ANL-003
12	Ø 60 0-500 °C THERMOMETER	M.ELK-EDM-DGT-006
13	SIGNAL LAMP	M.ELK-LMB-SNY-002
14	COVER	ARA-KNX.EPZ-0004
15	GLASS WICK	HCN-ELY-KZ-001
16	860MM*170MM*6MM GLASS	M.CAM-TMP-020
17	915*305*18 MM PIZZA STONE	M.TAS-FRN-PZ-003
18	1250 W 230V RESISTANCE	M.ELK-RZS-BRU-PZ6-003
19	WEIGHT SHAFT	YTL-KNX.EPZ-KS-0009
20	SUPPORT SHEET	YSC-KNX.EPZ-LZ-0045
21	M8 HANDLE	JP.M.AKS-KLP-BKL-002
22	COVER HANDLE	YSC-KNX.EPZ-LZ-0058
23	LID FITTING	YTL-KNX.GPZ-KS-0002

G SPARE PART LIST- EXPLODING DRAWINGS

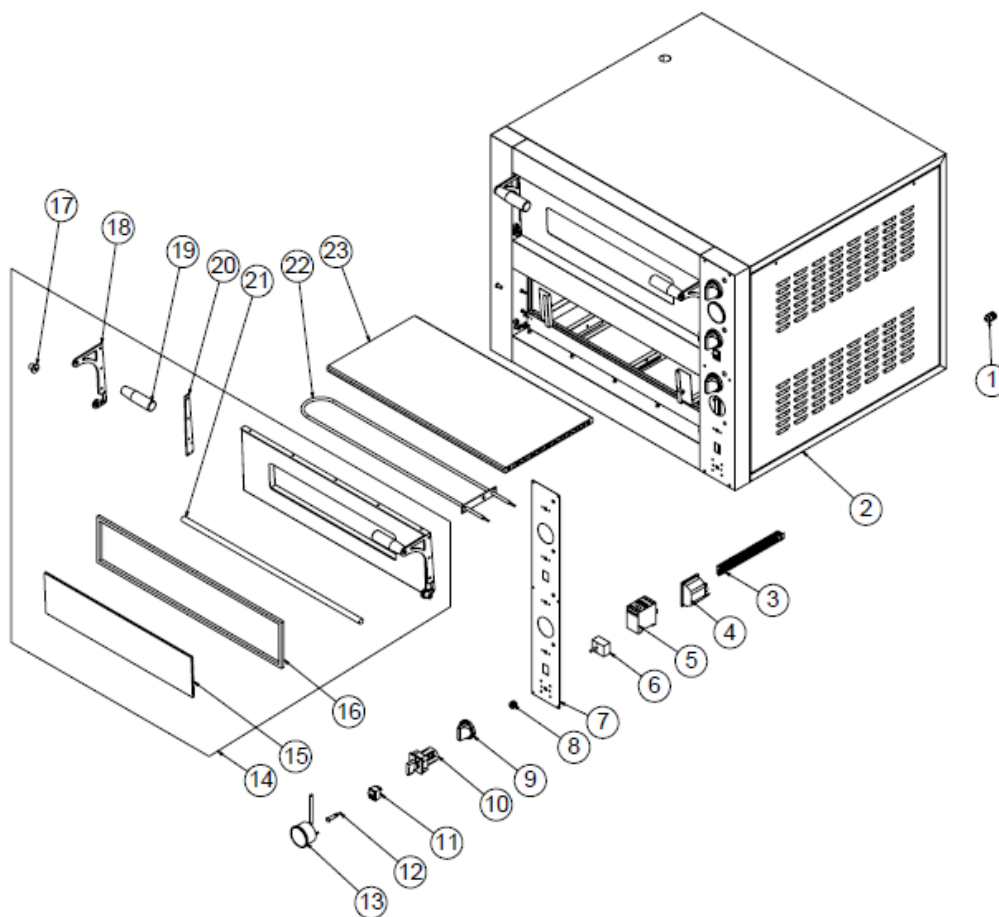

PIZZA OVEN (ELECTRICAL)

G SPARE PART LIST- EXPLODING DRAWINGS

PRODUCT CODE : EMP.8+8		
NO	PRODUCT NAME	P.CODE
1	PG-16 CABLE FITTING	JP.M.ELK-RKR-PLS-001
2	CHASSIS	-
3	COVER SHEET	YSC-KNX.EPZ-PN-0218
4	LAMP	JP.M.ELK-LMB-AMP-002
5	LC1K0901M7 CONTACTOR	JP.M.ELK-KNT-KNT-020
6	85-450 °C THERMOSTAT	M.ELK-MEK-TRM1-002
7	TICKET	M.AKS-ETK-ALM-013
8	BUTTON SOCKET	M.AKS-DGM-SKT-004
9	BUTTON	JP.M.AKS-DGM-MUH-005
10	3LF0122-4AC00 0-1 3*20A SWITCH	JP.M.ELK-SLT-PKO-003
11	0-1 KEY	M.ELK-SLT-ANL-003
12	SIGNAL LAMP	M.ELK-LMB-SNY-002
13	Ø 60 0-500 °C THERMOMETER	M.ELK-EDM-DGT-006
14	COVER	ARA-KNX.EPZ-0026
15	580MM*140MM*6MM GLASS	M.CAM-TMP-012
16	GLASS WICK	HCN-ELY-KZ-001
17	LID FITTING	YTL-KNX.GPZ-KS-0002
18	COVER HANDLE	YSC-KNX.EPZ-LZ-0058
19	M8 HANDLE	JP.M.AKS-KLP-BKL-002
20	SUPPORT SHEET	YSC-KNX.EPZ-LZ-0045
21	WEIGHT SHAFT	YTL-KNX.EPZ-KS-0045
22	220V 1250W RESISTANCE	M.ELK-RZS-BRU-PZ4-005
23	700*350*18 MM PIZZA STONE	M.TAS-FRN-PZ-014

G SPARE PART LIST- EXPLODING DRAWINGS

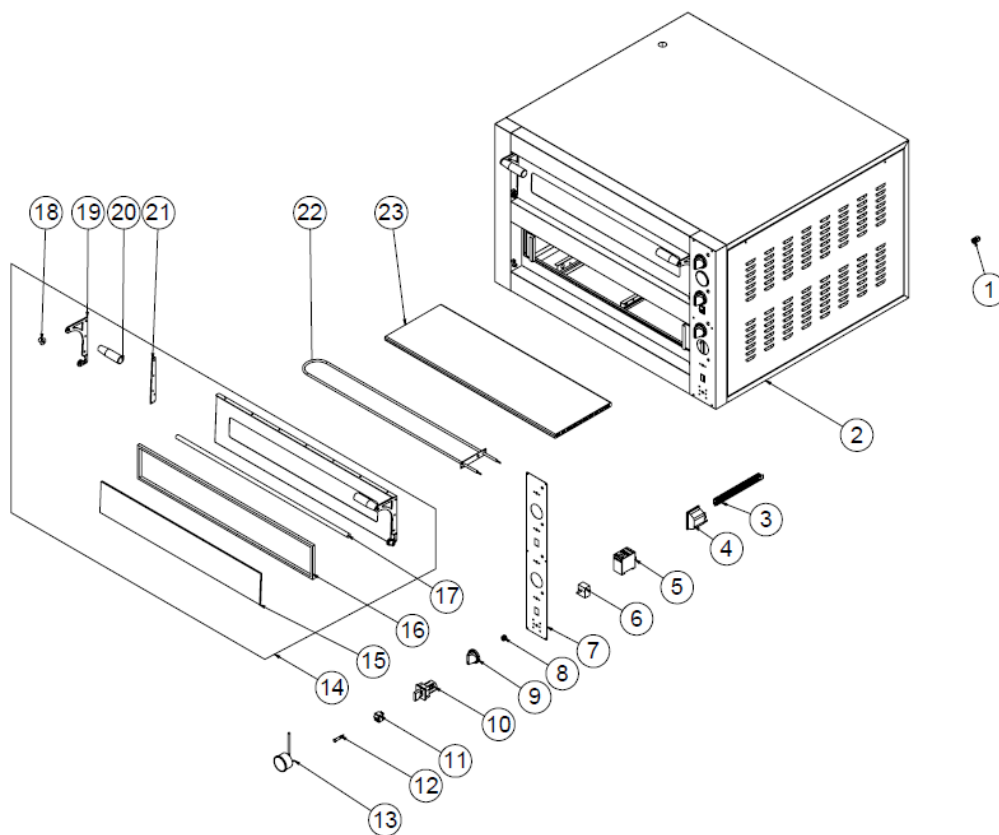

PIZZA OVEN (ELECTRICAL)

G SPARE PART LIST- EXPLODING DRAWINGS

PRODUCT CODE: EMP.9+9		
NO	PRODUCT NAME	P.CODE
1	PG-16 CABLE FITTING	JP.M.ELK-RKR-PLS-001
2	CHASSIS	-
3	COVER SHEET	YSC-KNX.EPZ-PN-0218
4	LAMP	JP.M.ELK-LMB-AMP-002
5	LC1K0901M7 CONTACTOR	JP.M.ELK-KNT-KNT-020
6	85-450 °C THERMOSTAT	M.ELK-MEK-TRM1-002
7	TICKET	M.AKS-ETK-ALM-013
8	BUTTON SOCKET	M.AKS-DGM-SKT-004
9	BUTTON	JP.M.AKS-DGM-MUH-005
10	3LF0122-4AC00 0-1 3*20A SWITCH	JP.M.ELK-SLT-PKO-003
11	0-1 KEY	M.ELK-SLT-ANL-003
12	SIGNAL LAMP	M.ELK-LMB-SNY-002
13	Ø 60 0-500 °C THERMOMETER	M.ELK-EDM-DGT-006
14	COVER	ARA-KNX.EPZ-0004
15	860MM*170MM*6MM GLASS	M.CAM-TMP-020
16	GLASS WICK	HCN-ELY-KZ-001
17	WEIGHT SHAFT	YTL-KNX.EPZ-KS-0009
18	LID FITTING	YTL-KNX.GPZ-KS-0002
19	COVER HANDLE	YSC-KNX.EPZ-LZ-0058
20	M8 HANDLE	JP.M.AKS-KLP-BKL-002
21	SUPPORT SHEET	YSC-KNX.EPZ-LZ-0045
22	1250 W 230V RESISTANCE	M.ELK-RZS-BRU-PZ6-003
23	915*305*18 MM PIZZA STONE	M.TAS-FRN-PZ-003

H ELECTRIC CIRCUIT SCHEMA

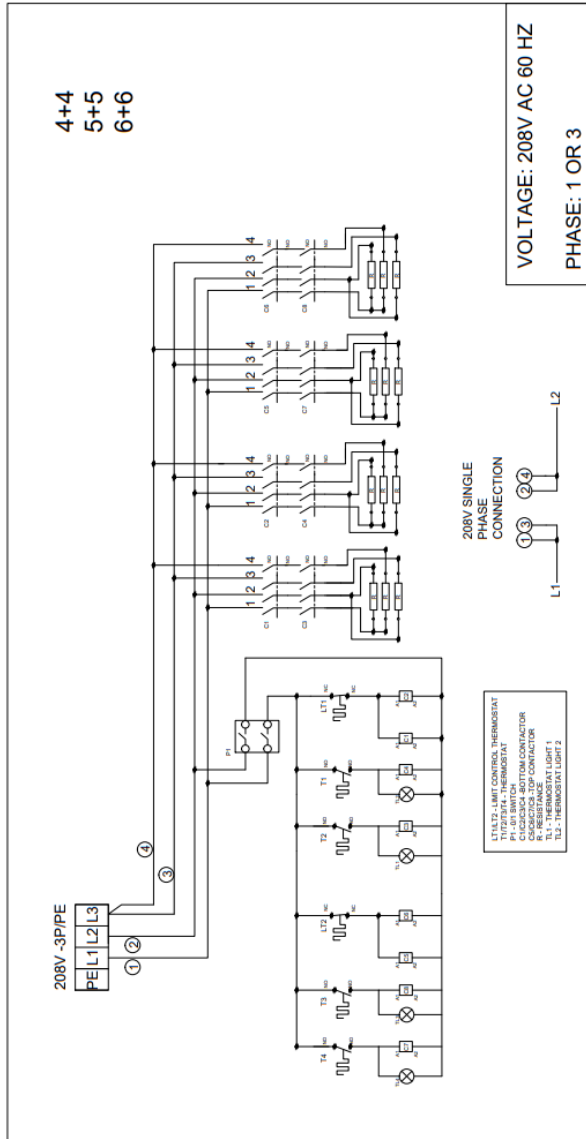

PIZZA OVEN (ELECTRICAL)

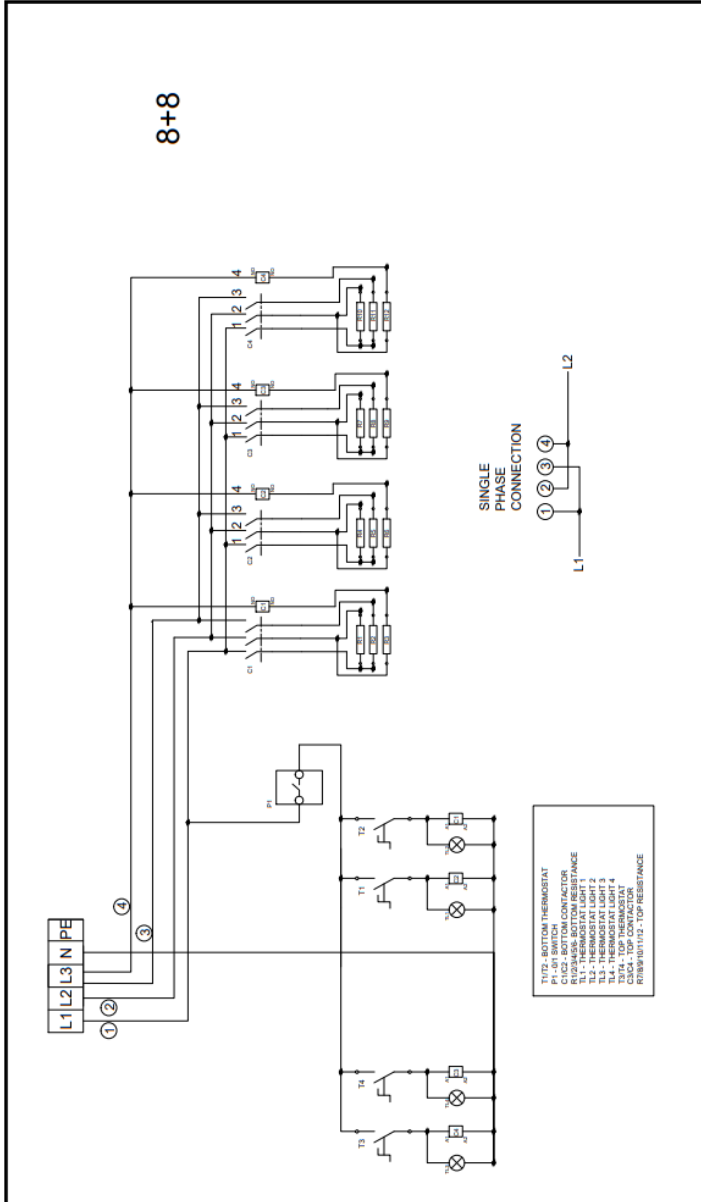

PIZZA OVEN (ELECTRICAL)

9+9

