



PIZZA OVEN (GAS)

CONTENTS

A	GENERAL INFORMATION.....	Page 2
A1	PRODUCT DESCRIPTION	Page 3
A2	TECHNICAL INFORMATION	Page 3
A3	TRANSPORTATION	Page 4
A4	UNPACKING	Page 4
B	INSTALLATION	Page 4
C	SAFETY INSTRUCTIONS.....	Page 5
D	OPERATION	Page 6
E	CLEANING & MAINTENANCE	Page 8
F	TROUBLESHOOTING	Page 9
G	INJECTOR CHANGE AND GAS SETTING	Page 10
H	GAS CONNECTION IMAGES	Page 11
I	SPARE PART LIST- EXPLODING DRAWING.....	Page 12
J	ELECTRIC CIRCUIT SCHEMA	Page 20

A GENERAL INFORMATION

Before installing the appliance, read operation and maintenance instructions carefully. Wrong installation and part changing may damage the product or may cause injury on people. These are not in our company's responsibility to damage the appliance intentionally, negligence, detriments because of disobeying instructions and regulations, wrong connections. Unauthorized intervention to appliance invalidates the warranty.

1. This instruction manual should be kept in a safe place for future reference.
2. **Installation should be made in accordance with ordinances and security rules of that country by a qualified service personnel.**
3. This appliance has to be used by trained person.
4. Please turn off the appliance immediately in the event of malfunction or failure. The appliance should be repaired only by authorized service personnel. Please demand original spare part.

PIZZA OVEN (GAS)

A1 PRODUCT DESCRIPTION

*The Professional Pizza Ovens (Gas), that provides high efficiency has been designed to be used in industrial kitchen.

Product Code	Dimensions (mm)	Weight (kg)	Packaging Dimensions (mm)
EMP.4G	1100x950x520	109	1200x1040x670
EMP.6G	1400x950x520	135	1470x1040x670
EMP.9G	1400x1250x520	175	1480x1300x670

A2 TECHNICAL INFORMATION

PRODUCT CODE	EMP.4G	EMP.6G	EMP.9G
INNER DIMENSIONS (mm)	615x615x150	915x615x150	915x915x150
CAPACITY	Ø300 mm x 4 pizza	Ø300 mm x 6 pizza	Ø300 mm x 9 pizza
GAS POWER LPG (KW)	15,5	15,5	24,2
GAS POWER NG (KW)	16,1	16,1	22
ELECTRIC POWER (KW)	12	18	24
OPERATING VOLTAGE (V)	1x230	1x230	1x230
GAS CONSUMPTION (NG)	1,70 m ³ /h	1,70 m ³ /h	2,30 m ³ /h
GAS CONSUMPTION (LPG)	1,21 kg/h	1,21 kg/h	1,90 kg/h
OPERATING PRESSURE (mbar)	30	30	30
FEEDING CABLE	3x2,5	3x2,5	3x2,5

A3 TRANSPORTATION

*This appliance can not be moved by hand from area to area. It must be moved on pallet with forklift truck.

A4 UNPACKING

*Please unpack the package according to the security codes and ordinances of current country and get rid from the pack.Parts which contacts with food are produced by stainless steel.All plastic parts are marked by material's symbol.

*Please check that all the parts of appliance had come completely and if they are damaged or not during the shipping.

B INSTALLATION

*Please place the product to straight and sturdy ground,please take necessary steps against possibility of overturn.

*Technician who will serve for installation and service for the appliance must be professional on this subject and must have installation and service licenses by the company.

*Connection to Gas Fitment must be done by authorized person.

*The area where the appliance is must have enough ventilation and vent-hole.

*The appliance must be connected correctly according to local and national gas standards of your country.

*The appliance gas entrances are indicated with "G" label on the body.



This appliance must be connected to an earthed outlet in accordance with safety rules and standards.

*Appliance's earthing must be connected to earthing line on panel which is nearest to electric installation.

*Connection to the main fuse and leak current fuse must be done in accordance with the current regulations.











*Connection to gas fitment must be done with suitable diameter metal flex pipe and spheric valve.The spheric valve must be immobilized to a place that is far away from heat and accessible during the danger.After gas entrance connection done,gas leakages must be checked.

*According to the datas on appliance information plate,gas and pressure must be adjusted.If the gas type that is adjusted is not the suitable with gas type that is at installation place,apply the instructions that is about adjustment of different gas type (**Event :G**)

*For easy cleaning and maintenance of the appliance, there must be at least 50 cm spaces both right and left side of the appliance.

PIZZA OVEN (GAS)

C SAFETY INSTRUCTIONS

-  *Do not use the appliance in insufficient lighted place.
-  *Do not touch the moving attachments while the appliance operates.
-  *Do not install the appliance in the presence of flammable or explosive materials.
-  *Do not operate the appliance when the machine is empty.
-  *Do not load so less or more than appliance's capacity.
-  *Do not attempt to use the appliance without suitable protective equipments.
-  *Do not open the oven lid when the cooking compartment is hot.
-  *Because of any reason if there is a fire or flame flare where the appliance is used, turn off all gas valves and electric contactor switch quickly and use fire extinguisher. Never use water to extinguish the fire.
-  *If there is gas leakage where the appliance is, do not fire absolutely and do not use electric.
-  *Definitely do not allow to check the sealing with flame.
-  *The chimney hood must be installed to the oven as it covers over the oven completely. The chimney hood pipes can be used without fan till maximum 3 metres. If the chimney hood pipe distance is more than 3 metres, the fan must be used.

D OPERATION

*Control Panel;

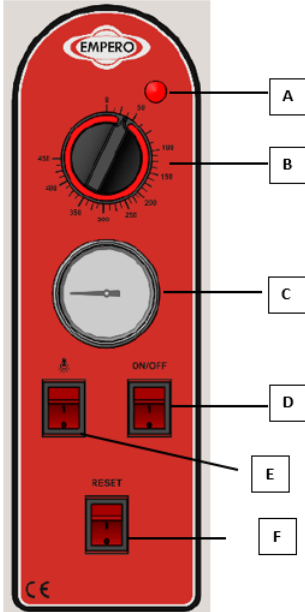

- A : Indicator lamp
- B : Heat setting button
- C : Analog indicator
- D : ON/OFF button
- E : Inner lighting button
- F : Reset button

*Operating;

- Clean the inner and outer surface of the appliance with warm moist cloth and then dry before operating.
- Plug in the appliance and turn on the gas valve.
- Switch ON.
- Adjust the thermostat heat setting to desired heat.
- Before inserting the products to the appliance,preheat it.For this operate the appliance over 60°C for 5-10 min.
- Place the pizzas to the oven and close the lid.
- In order to see the product without opening the lid,press lighting button.
- When the operation is completed ,switch the thermostat to OFF position and unplug the appliance.

PIZZA OVEN (GAS)

E CLEANING & MAINTENANCE

➤ **CLEANING AND MAINTENANCE AFTER EVERY USE**

- Be sure that gas and electric connections are off before cleaning.
- Clean the inside of the oven with soft cloth by using oil solvent spray, before the appliance gets cooled exactly.
- Do not use abrasive cleaning chemicals as these can leave harmful residues.
- Do not use pressure water or vapor during the cleaning.
- Do not clean the appliance with the materials that may damage to chrome material.

➤ **PERIODIC CLEANING AND MAINTENANCE**

- Maintenance should be done by qualified person.
- Get the periodic maintenance of the appliance once in every 15 days.
- Check the lighting lamp according to frequency of use.
- Check the cooking stones in periodic times. Change the broken and deformed stones.
- Check the gas connection hoses in periodic time. If there is slit, hole..etc, change the hoses.
- Ventilate the area where the appliance is in periodic times.

F TROUBLESHOOTING

THE APPLIANCE DOESN'T OPERATE	<ol style="list-style-type: none"> 1. Check if the gas connection is done or not. 2. If the hoses that have gas entrance lose gas due to slit,hole.etc.,the appliance is not operated. 3. Check the electrical connections and voltage. 4. Check if the fuse is on or off.
--------------------------------------	--

THE APPLIANCE DOESN'T COOK WELL	<ol style="list-style-type: none"> 1. Check if it is operated at suitable gas setting or not. 2. Check the heat settings.
--	---

THE APPLIANCE STOPPED	<ol style="list-style-type: none"> 1. When the oven operating temperature is more than maximum temperature,the oven will get STOP position automatically. 2. When there is gas leakage,if there is solenoid gas stopper alarm in the area,gas flow is stopped and the appliance is not operated.Ventilate the area with air vent. 3. Check the burner.
------------------------------	---

RESET BUTTON LIGHT DOESN'T SIGNAL	<ol style="list-style-type: none"> 1. Check if the gas comes to the appliance. 2. Check if the sparking plug contacts with body or not. 3. Check if the sparking plug can fire or not.Lamp is not on.
--	--

LAMP IS NOT ON.	<ol style="list-style-type: none"> 1. The lamp may be broken.Change it.
------------------------	--

<ul style="list-style-type: none"> • If cooking at pizza ovens (gas) is not done at suitable quality • If any function of security doesn't work <ul style="list-style-type: none"> ➤ Do not use the appliance.
--

***If these problems are still going on,contact with our authorized services.**

PIZZA OVEN (GAS)

G INJECTOR CHANGE AND GAS SETTING

PIZZA OVENS (GAS) BURNER-INJECTOR CHANGE CHART

NG / LPG		EMP.4G		EMP.6G		EMP.8G		EMP.9G		
		Ø mm	X	Ø mm	X	Ø mm	X	Ø mm	X	
2	G20	<u>3</u>	<u>1x</u>	<u>3,5</u>	<u>1x</u>	<u>0</u>	<u>0</u>	<u>3,5</u>	<u>1x</u>	
	G25	<u>3</u>	<u>1x</u>	<u>3,5</u>	<u>1x</u>	<u>0</u>	<u>0</u>	<u>3,5</u>	<u>1x</u>	
3	G30	30 mbar	<u>2</u>	<u>1x</u>	<u>2</u>	<u>1x</u>	<u>0</u>	<u>0</u>	<u>2,5</u>	<u>1x</u>
		50 mbar	<u>2</u>	<u>1x</u>	<u>2</u>	<u>1x</u>	<u>0</u>	<u>0</u>	<u>2,5</u>	<u>1x</u>
	G31	37 mbar	<u>2</u>	<u>1x</u>	<u>2</u>	<u>1x</u>	<u>0</u>	<u>0</u>	<u>2,5</u>	<u>1x</u>
		50 mbar	<u>2</u>	<u>1x</u>	<u>2</u>	<u>1x</u>	<u>0</u>	<u>0</u>	<u>2,5</u>	<u>1x</u>

Change of the burner injector

1. The oven must be dispatched from the factory as it works with NG. The injectors of the ovens that will be worked with LPG must be changed by authorized service according to datas on the chart.
2. Increase the gas by turning yellow part on the gas block. If it is turned (-) direction, the gas is reduced. (Image 1)

H GAS CONNECTION IMAGES

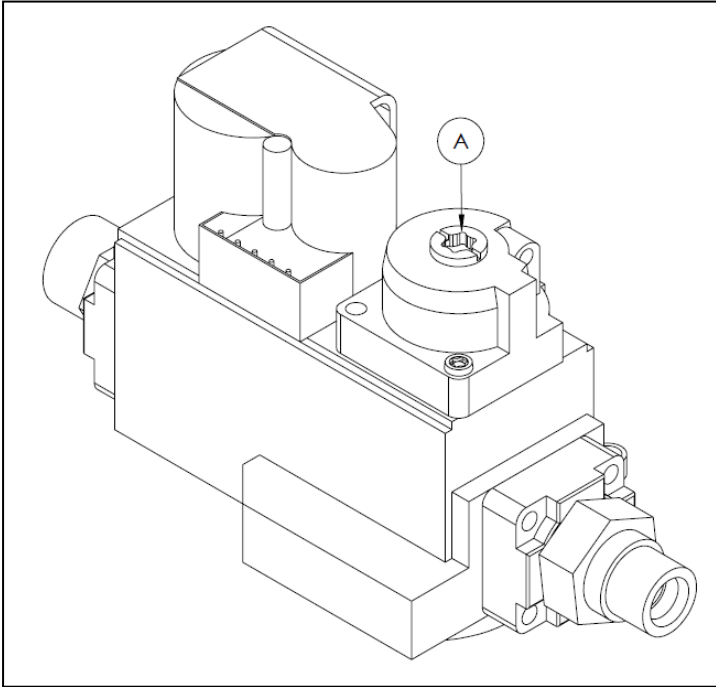

Image 1

I SPARE PART LIST-EXPLODING DRAWING

PRODUCT CODE: EMP.4G		
NO	PRODUCT NAME	P.CODE
1	COVER SHEET	YSC-KNX.GPZ-PN-0068
2	3*1.00 CABLE	JP.M.ELK-PWR-PBK-001
3	PG-11 CABLE FITTING	M.ELK-RKR-PLS-003
4	CONNECTION 1/2	JP.M.MEK-TES-SRI-014
5	1/2 FLANGE 45900400-102B	M.GAZ-BLK-HNW-003
6	IGNITION BOARD S4565A2019B	M.GAZ-BLK-HNW-002
7	GAS BLOCK VK4105A1001B	M.GAZ-BLK-HNW-001
8	GAS BLOCK INLET FITTING	YTL-KNX.GPZ-KS-0001
9	BRASS FITTING 3-8 YELLOW	M.GAZ-TES-SRI-005
10	FLEXIABLE GAS PIPEØ10 MM 80 CM 3/8	M.GAZ-TES-SPR-021
11	COVER SHEET	YSC-KNX.EPZ-PN-0218
12	LAMP	JP.M.ELK-LMB-AMP-002
13	85-450 °C THERMOSTAT	M.ELK-MEK-TRM1-002
14	TICKET	JP.M.AKS-ETK-LKS-018
15	BUTTON SOCKET	M.AKS-DGM-SKT-004
16	BUTTON	JP.M.AKS-DGM-MUH-005
17	0-1 KEY	M.ELK-SLT-ANL-003
18	BUTTON	JP.M.ELK-SLT-BTL-001
19	Ø 60 0-500 °C THERMOMETER	M.ELK-EDM-DGT-006
20	SIGNAL LAMP	M.ELK-LMB-SNY-002
21	COVER	ARA-KNX.KFR-0002
22	615MM*175MM*6.00MM GLASS	M.CAM-TMP-003
23	GLASS WICK	HCN-ELY-KZ-001
24	LID WEIGHT SHAFT	YTL-KNX.GPZ-KS-0003
25	REINFORCEMENT SHEET	YSC-KNX.GPZ-LZ-0022
26	M8 HANDLE	JP.M.AKS-KLP-BKL-002
27	CONEXION SHEET	YSC-KNX.GPZ-LZ-0003
28	LID FITTING	YTL-KNX.GPZ-KS-0002
29	IGNITION PLUG	M.GAZ-CKM-BUJI-001
30	IGNITION PLUG	M.GAZ-CKM-BUJI-007
31	615*606*18 MM PIZZA STONE	M.TAS-FRN-PZ-001
32	3/8 16*1.5 M.8 0.75 L SHAPED PIPE	M.GAZ-TES-SRI-023
33	CONEXION NUT	YTL-KNX.PLF-KS-0001
34	INJECTOR M8*0.75 Ø 3.00 MM.	M.GAZ-ENJ-NG-009
35	INJECTOR M8*0.75 Ø2.00 MM.	M.GAZ-ENJ-NG-010
36	500.500*4P BURNER	M.GAZ-BRL-SMC-005
37	CHASSIS	-
38	CHIMNEY SHEET	YSC-KNX.GPZ-PN-0093
39	CHIMNEY SHEET	YSC-KNX.GPZ-LZ-0156
40	CHIMNEY SHEET	YSC-KNX.GPZ-LZ-0155
41	CHIMNEY SHEET	YSC-KNX.GPZ-PN-0058
42	OUTER BACK SHEET	YSC-KNX.GPZ-PN-0079

PIZZA OVEN (GAS)

I SPARE PART LIST-EXPLODING DRAWING

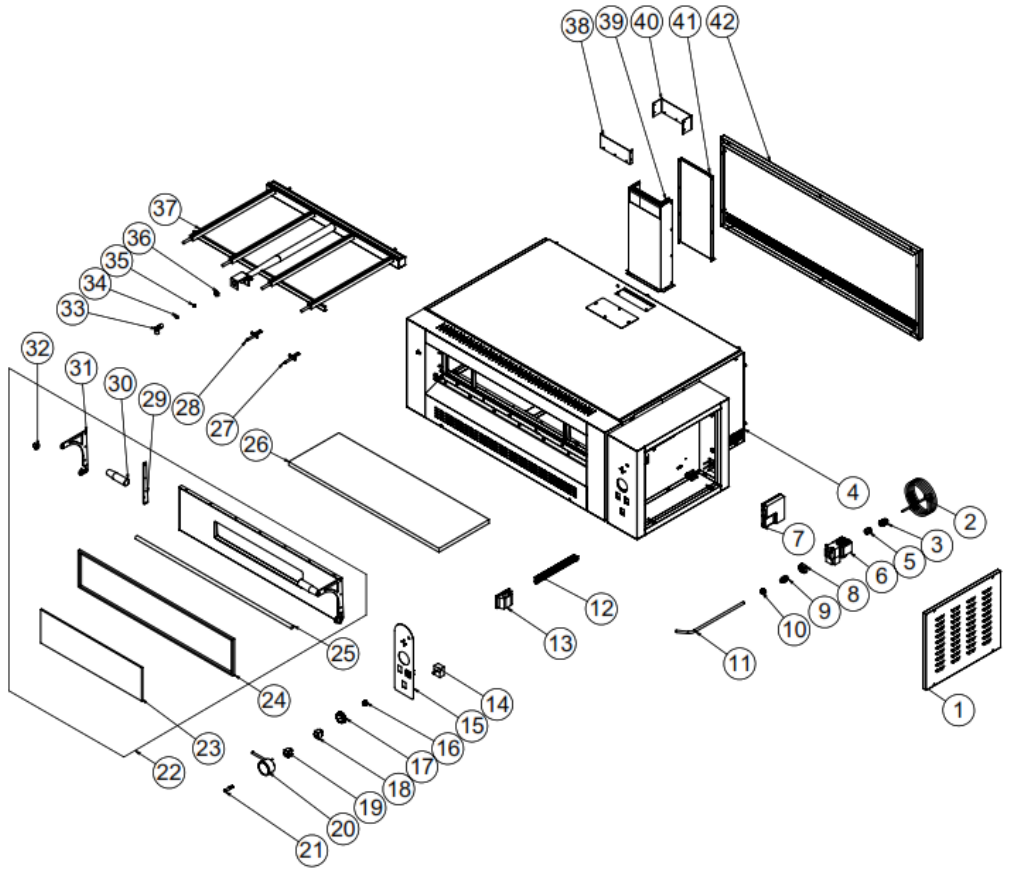

EMP.6G

I SPARE PART LIST-EXPLODING DRAWING

PRODUCT CODE: EMP.6G		
NO	PRODUCT NAME	P.CODE
1	COVER SHEET	YSC-KNX.GPZ-PN-0068
2	3*1.00 CABLE	JP.M.ELK-PWR-PBK-001
3	PG-11 CABLE FITTING	M.ELK-RKR-PLS-003
4	CHASSIS	-
5	CONNECTION 1/2	JP.M.MEK-TES-SRI-014
6	GAS BLOCK VK4105A1001B	M.GAZ-BLK-HNW-001
7	IGNITION BOARD S4565A2019B	M.GAZ-BLK-HNW-002
8	1/2 FLANGE 45900400-102B	M.GAZ-BLK-HNW-003
9	GAS BLOCK INLET FITTING	YTL-KNX.GPZ-KS-0001
10	BRASS FITTING 3-8 YELLOW	M.GAZ-TES-SRI-005
11	FLEXIBLE GAS PIPEØ10 MM 100 CM 3/8	M.GAZ-TES-SPR-029
12	COVER SHEET	YSC-KNX.EPZ-PN-0218
13	LAMP	JP.M.ELK-LMB-AMP-002
14	85-450 °C THERMOSTAT	M.ELK-MEK-TRM1-002
15	TICKET	JP.M.AKS-ETK-LKS-018
16	BUTTON SOCKET	M.AKS-DGM-SKT-004
17	BUTTON	JP.M.AKS-DGM-MUH-005
18	0-1 KEY	M.ELK-SLT-ANL-003
19	BUTTON	JP.M.ELK-SLT-BTL-001
20	Ø 60 0-500 °C THERMOMETER	M.ELK-EDM-DGT-006
21	SIGNAL LAMP	M.ELK-LMB-SNY-002
22	COVER	ARA-KNX.GPZ-0001
23	615MM*175MM*6.00MM GLASS	M.CAM-TMP-003
24	GLASS WICK	HCN-ELY-KZ-001
25	LID WEIGHT SHAFT	YTL-KNX.GPZ-KS-0004
26	915*305*18 MM PIZZA STONE	M.TAS-FRN-PZ-003
27	IGNITION PLUG	M.GAZ-CKM-BUJI-001
28	IGNITION PLUG	M.GAZ-CKM-BUJI-007
29	REINFORCEMENT SHEET	YSC-KNX.GPZ-LZ-0022
30	M8 HANDLE	JP.M.AKS-KLP-BKL-002
31	CONEXION SHEET	YSC-KNX.GPZ-LZ-0003
32	LID FITTING	YTL-KNX.GPZ-KS-0002
33	3/8 16*1.5 M.8 0.75 L SHAPED PIPE	M.GAZ-TES-SRI-023
34	INJECTOR M8*0.75 Ø 3.00 MM.	M.GAZ-ENJ-NG-009
35	INJECTOR M8*0.75 Ø2.00 MM.	M.GAZ-ENJ-NG-010
36	CONEXION NUT	YTL-KNX.PLF-KS-0001
37	800.500*4P BURNER	M.GAZ-BRL-SMC-006
38	CHIMNEY SHEET	YSC-KNX.GPZ-LZ-0156
39	CHIMNEY SHEET	YSC-KNX.GPZ-PN-0093
40	CHIMNEY SHEET	YSC-KNX.GPZ-LZ-0155
41	CHIMNEY SHEET	YSC-KNX.GPZ-PN-0058
42	OUTER BACK SHEET	YSC-KNX.GPZ-PN-0085

PIZZA OVEN (GAS)

I SPARE PART LIST-EXPLODING DRAWING

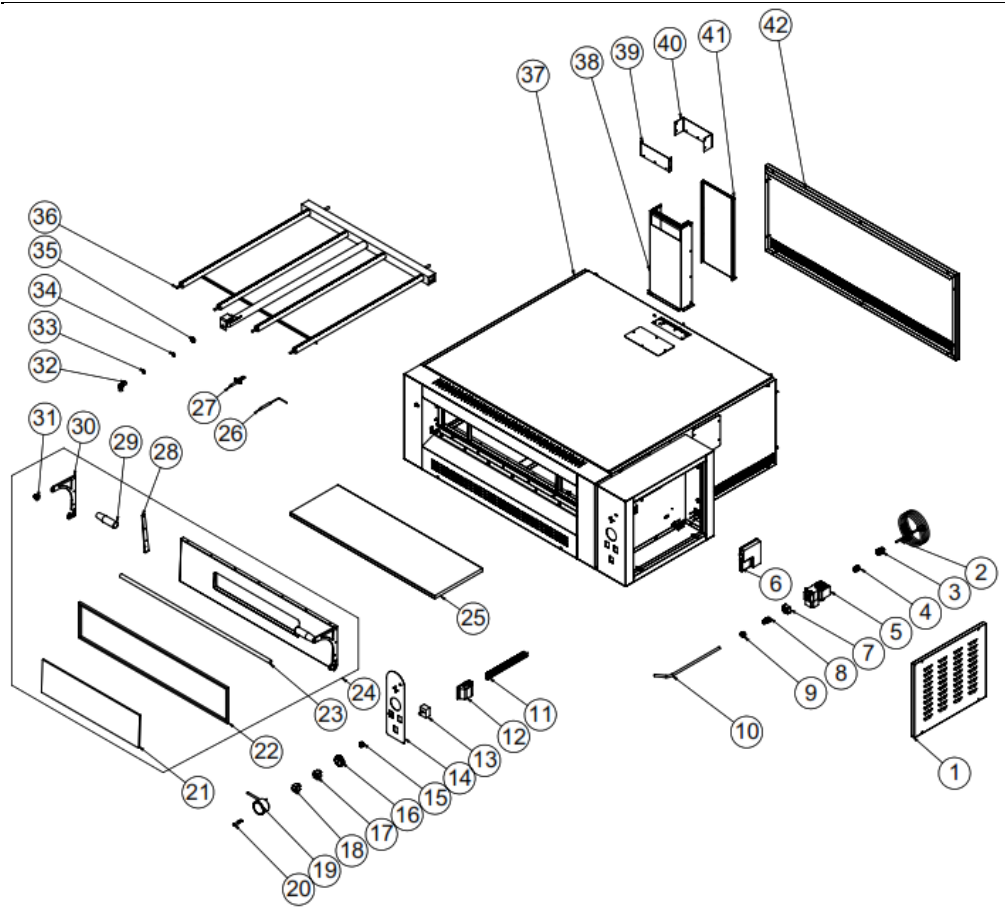

EMP.9G

I SPARE PART LIST-EXPLODING DRAWING

PRODUCT CODE: EMP.9G		
NO	PRODUCT NAME	P.CODE
1	COVER SHEET	YSC-KNX.GPZ-PN-0068
2	3*1.00 CABLE	JP.M.ELK-PWR-PBK-001
3	PG-11 CABLE FITTING	M.ELK-RKR-PLS-003
4	CONNECTION 1/2	JP.M.MEK-TES-SRI-014
5	GAS BLOCK VK4105A1001B	M.GAZ-BLK-HNW-001
6	IGNITION BOARD S4565A2019B	M.GAZ-BLK-HNW-002
7	1/2 FLANGE 45900400-102B	M.GAZ-BLK-HNW-003
8	GAS BLOCK INLET FITTING	YTL-KNX.GPZ-KS-0001
9	BRASS FITTING 3-8 YELLOW	M.GAZ-TES-SRI-005
10	FLEXIABLE GAS PIPEØ10 MM 80 CM 3/8	M.GAZ-TES-SPR-021
11	COVER SHEET	YSC-KNX.EPZ-PN-0218
12	LAMP	JP.M.ELK-LMB-AMP-002
13	85-450 °C THERMOSTAT	M.ELK-MEK-TRM1-002
14	TICKET	JP.M.AKS-ETK-LKS-018
15	BUTTON SOCKET	M.AKS-DGM-SKT-004
16	BUTTON	JP.M.AKS-DGM-MUH-005
17	0-1 KEY	M.ELK-SLT-ANL-003
18	BUTTON	JP.M.ELK-SLT-BTL-001
19	Ø 60 0-500 °C THERMOMETER	M.ELK-EDM-DGT-006
20	SIGNAL LAMP	M.ELK-LMB-SNY-002
21	615MM*175MM*6.00MM GLASS	M.CAM-TMP-003
22	GLASS WICK	HCN-ELY-KZ-001
23	LID WEIGHT SHAFT	YTL-KNX.GPZ-KS-0004
24	COVER	ARA-KNX.GPZ-0001
25	915*305*18 MM PIZZA STONE	M.TAS-FRN-PZ-003
26	IGNITION PLUG	M.GAZ-CKM-BUJI-001
27	IGNITION PLUG	M.GAZ-CKM-BUJI-007
28	REINFORCEMENT SHEET	YSC-KNX.GPZ-LZ-0022
29	M8 HANDLE	JP.M.AKS-KLP-BKL-002
30	CONEXION SHEET	YSC-KNX.GPZ-LZ-0003
31	LID FITTING	YTL-KNX.GPZ-KS-0002
32	3/8 16*1.5 M.8 0.75 L SHAPED PIPE	M.GAZ-TES-SRI-023
33	ENJEKTOR M8*0.75 Ø 2.50 MM.	M.GAZ-ENJ-NG-008
34	INJECTOR M8*0.75 Ø 3.50 MM.	M.GAZ-ENJ-NG-020
35	CONEXION NUT	YTL-KNX.PLF-KS-0001
36	800.800*4P BURNER	M.GAZ-BRL-SMC-007
37	CHASSIS	-
38	CHIMNEY SHEET	YSC-KNX.GPZ-PN-0093
39	CHIMNEY SHEET	YSC-KNX.GPZ-LZ-0156
40	CHIMNEY SHEET	YSC-KNX.GPZ-LZ-0155
41	CHIMNEY SHEET	YSC-KNX.GPZ-PN-0058
42	OUTER BACK SHEET	YSC-KNX.GPZ-PN-0085

PIZZA OVEN (GAS)

J ELECTRIC CIRCUIT SCHEMA

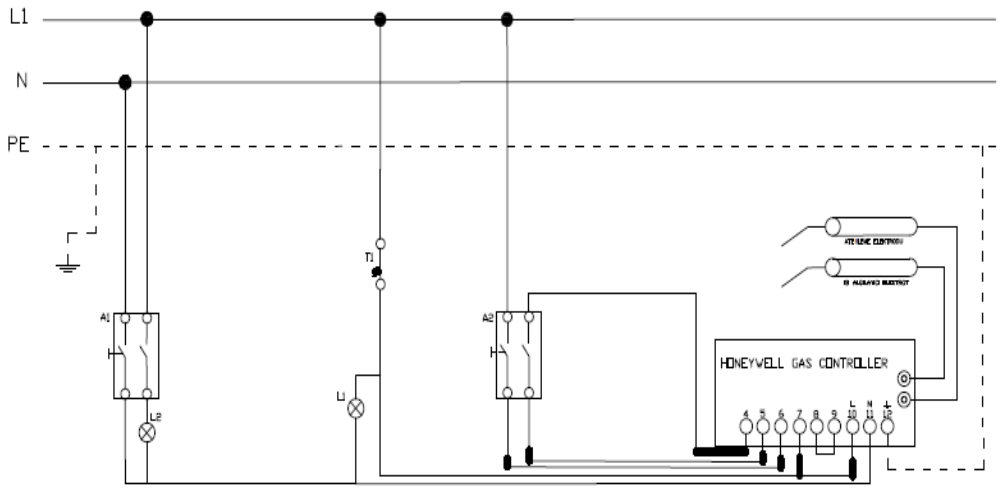

A1	Inner lighting switch
A2	HONEYWEL card reset switch
L1	Thermostat signal lamp
T1	Thermostat (50-400 °C)