



GAS TANDOORI OVEN

CONTENTS

A	GENERAL INFORMATION	Page	2
A1	PRODUCT DESCRIPTION	Page	3
A2	TECHNICAL INFORMATION	Page	3
A3	TRANSPORTATION	Page	3
A4	UNPACKING	Page	4
B	INSTALLATION	Page	4
C	SAFETY INSTRUCTIONS	Page	5
D	OPERATION	Page	6
E	CLEANING & MAINTENANCE	Page	7
F	TROUBLESHOOTING	Page	8
G	INJECTOR CHANGE AND GAS SETTING	Page	9
H	GAS CONNECTION IMAGES	Page	10
I	SPARE PART LIST- EXPLODING DRAWING	Page	11

A GENERAL INFORMATION

Before installing the appliance, read operation and maintenance instructions carefully. Wrong installation and part changing may damage the product or may cause injury on people. These are not in our company's responsibility to damage the appliance intentionally, negligence, detriments because of disobeying instructions and regulations, wrong connections. Unauthorized intervention to appliance invalidates the warranty.

1. This instruction manual should be kept in a safe place for future reference.
2. **Installation should be made in accordance with ordinances and security rules of that country by a qualified service personnel.**
3. This appliance has to be used by trained person.
4. Please turn off the appliance immediately in the event of malfunction or failure. The appliance should be repaired only by authorized service personnel. Please demand original spare part.



GAS TANDOORI OVEN

A1 PRODUCT DESCRIPTION

*The Professional Gas tandoori oven, that provides high efficiency has been designed to be used in industrial kitchens.

Product Code	Dimensions (mm)	Weight (kg)	Packaging Dimensions (mm)
EMP.TDR.01	706x1018x1440	291	760x1130x1441

A2 TECHNICAL INFORMATION

CODE	EMP.TDR.01
POWER LPG / NG (KW)	39,7 / 64,8
GAS CONSUMPTION (NG)	6,85 m ³ /h
GAS CONSUMPTION (LPG)	4,86 kg/h
INTERIOR TANK DIMENSION (mm)	66

A3 TRANSPORTATION

*This appliance can not be moved by hand from area to area. Therefore Use a hauling truck (forklift or pallet jack) to move the appliance. (The lifting arms of the of forklift or pallet jack must reach up to more than half part of t appliance underneath).

A4 UNPACKING

*Please unpack the package according to the security codes and ordinances of current country and get rid from the pack.Parts which contacts with food are produced by stainless steel.All plastic parts are marked by material's symbol.

*Please check that all the parts of appliance had come completely and if they are damaged or not during the shipping.

B INSTALLATION

*Please place the product to straight and sturdy ground,please take necessary steps against possibility of overturn.

*Technician who will serve for installation and service for the appliance must be professional on this subject and must have installation and service licenses by the company.

*Connection to Gas Fitment must be done by authorized person.

*The area where the appliance is must have enough ventilation and vent-hole.

*The appliance must be connected correctly according to local and national gas standards of your country.

*The appliance gas entrances are indicated with "G" label on the body.











*Connection to gas fitment must be done with suitable diameter metal flex pipe and spheric valve.The spheric valve must be immobilized to a place that is far away from heat and accessible during the danger.After gas entrance connection done,gas leakages must be checked.

*According to the datas on appliance information plate,gas and pressure must be adjusted.If the gas type that is adjusted is not the suitable with gas type that is at installation place,apply the instructions that is about adjustment of different gas type. (Event :G)

*If the location where Ovens placed is covered with nonflammable heat insulation material,the distance between them must be 5 cm.Otherwise it should be at least 20 cm.The appliance should be operated under the chimney hood.

GAS TANDOORI OVEN

C SAFETY INSTRUCTIONS

-  *Do not use the appliance in insufficient lighted place.
-  *Do not touch the moving attachments while the appliance operates.
-  *Do not install the appliance in the presence of flammable or explosive materials.
-  *Do not operate the appliance when the machine is empty.
-  *Do not load so less or more than appliance's capacity.
-  *Do not attempt to use the appliance without suitable protective equipments.
-  *Because of any reason if there is a fire or flame flare where the appliance is used, turn off all gas valves and electric contactor switch quickly and use fire extinguisher. Never use water to extinguish the fire.
-  *If there is gas leakage where the appliance is, do not fire absolutely and do not use electric.
-  *Definitely do not allow to check the sealing with flame.
-  *Do not use the gas stock pot stove that doesn't have safety valve in closed area.

D OPERATION

*Control Panel:

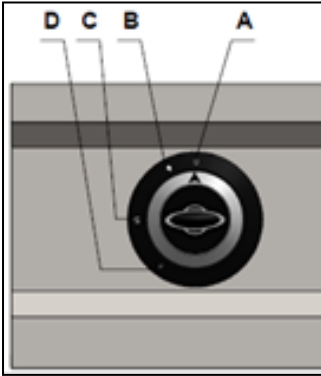

- A : ON/OFF
- B : IGNITION POSITION
- C : FULL FLAME POSITION
- D : HALF FLAME POSITION

* Operating:

- According to type of use, make gas entrance connection from behind the grill. Because the machine is operated with LPG and NG.
- Turn on the gas valves.
- To activate the apparatus, turn the button to the 'fire' position, click inside and the lighter.
- Before using the apparatus, run it on 350 degrees for an hour time.
- If the bread will be cooked after the oven is heated, the dough of the bread should be placed on interior walls.
- If the meat will be cooked, the meat should be placed on sishes and placed through the holes on the cover sheet metal.
- While the apparatus is not running, switch the button to 'off position and turn off the main gas valve.

GAS TANDOORI OVEN

E CLEANING & MAINTENANCE

➤ **CLEANING AND MAINTENANCE AFTER EVERY USE**

- Turn off the gas connection before cleaning.
- Clean the outer surface of the appliance with a wet cloth and chrome shiner.
- Do not use abrasive cleaning chemicals as these can leave harmful residues.
- Do not wash the appliance with pressure water.
- Do not clean the appliance with a materials that may hurt chrome material.
- Wash the grills with hot water and then dry after every use.

➤ **PERIODIC CLEANING AND MAINTENANCE**

- Maintenance should be done by qualified person.
- These parts ; Gas storage,thermocouples,taps,burner,lighter and spark plug cable are not maintained so they need to be changed when they have error.
- Check the gas connection hoses in periodic time.If there is slit,hole..etc,change the hoses.
- Ventilate the area where the device is in periodic times.



GAS TANDOORI OVEN

F TROUBLESHOOTING

THE APPLIANCE DOESN'T OPERATE	<ol style="list-style-type: none">1. Check if the gas connection is done or not.2. If the hoses that have gas entrance lose gas due to slit,hole.etc.,the appliance is not operated.
--------------------------------------	---

THE APPLIANCE DOESN'T COOK WELL	<ol style="list-style-type: none">1. Check if it is operated at suitable gas setting or not.
--	--

THE APPLIANCE STOPPED	<ol style="list-style-type: none">1. EMP.TDR.01 the gas flow is stopped automatically when the flame is off due to having gas tap that has safety valve.In this situation the appliance is not operated.2. When there is gas leakage,if there is solenoid gas stopper alarm,gas flow is stopped and the appliance is not operated.Ventilate the area through the agency of vent-hole.
------------------------------	--

- If cooking at ovens is not done at suitable quality
- If any function of security doesn't work
 - Do not use the appliance.

***If these problems are still going on,contact with our authorized services.**

GAS TANDOORI OVEN

G INJECTOR CHANGE AND GAS SETTING

OVEN-BURNER INJECTOR CHANGE CHART

Gas Group	Gas		EMP.TDR.01	
			Injector Ø mm	X
2	G20		4,5	1x
	G25		4,5	1x
3	G30	30 mbar	4	1x
		50 mbar	4	1x
	G31	37 mbar	4	1x
		50 mbar	4	1x

Burner Injectors Change;

1. Change "B" injector with consideration of valve on table above .for this purpose first unscrew all "F" screws. Then unscrew "C" nuts. Pull "D" Injector fastening plate to back. Disassemble the Valves "E" and remove the injector. (Image 1)
2. In case of involuntary flame out ; "E" safety valve will cut gas leakage if "F" thermo doesn't realize the flame. (Image 1)
3. While the apparatus is on the 'low fire' position, the adjustment of 'high/low' fire can be done through the shown screw. (Image 2)

H GAS CONNECTION IMAGES

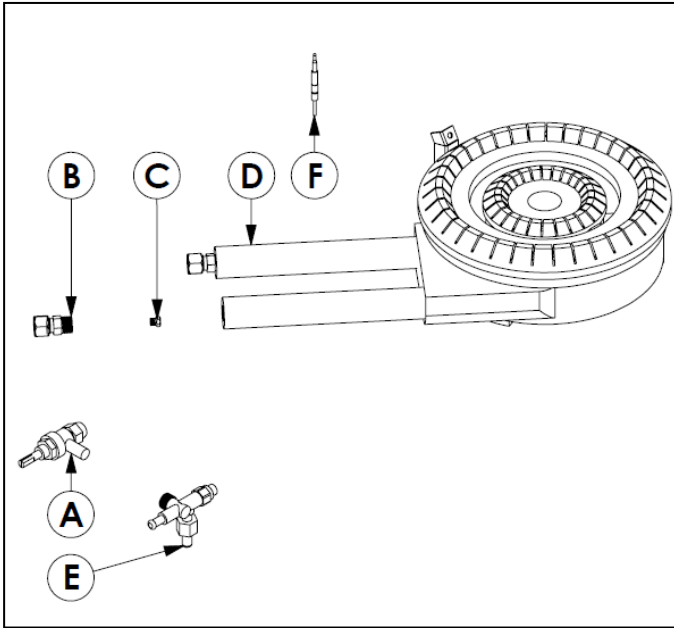

Image 1

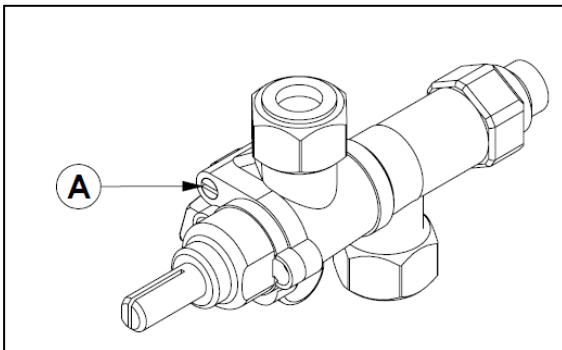
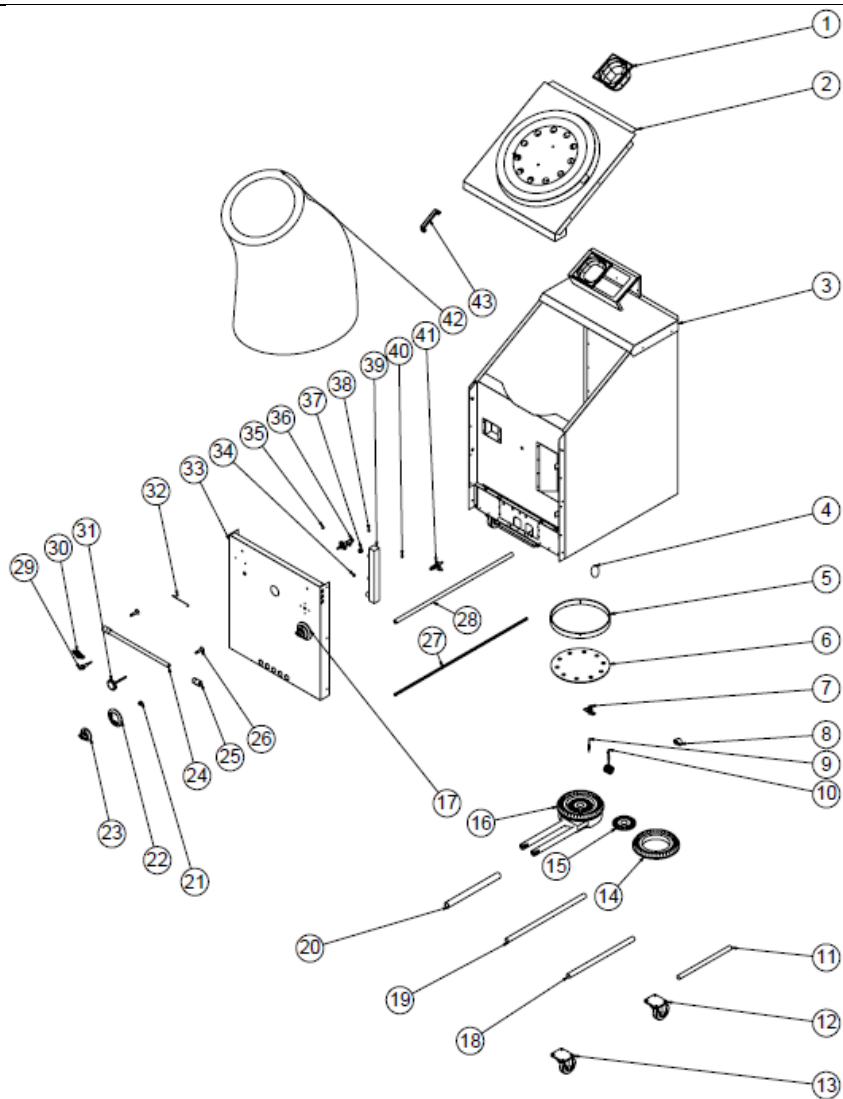

Image 2

GAS TANDOORI OVEN

I SPARE PART LIST-EXPLODING DRAWING



I SPARE PART LIST-EXPLODING DRAWING

PRODUCT CODE: EMP.TDR.01

NO	PRODUCT NAME	P.CODE
1	1/6*100 GN BATHTUB	M.MTS-KNX-GNK-1/6-100
2	UPPER PAN SHEET	M.MTS-JP-TDR-001
3	CHASSIS	-
4	LARGE LAV STONE	M.TAS-LAV-007
5	TRAYLATERAL SHEET	YSC-KNX.TDR-LZ-0009
6	TRAYSHEET	YSC-KNX.TDR-LZ-0008
7	PILOT GROUP TEAM	M.GAZ-PLT-PLT-001
8	BRACKET	JP.M.GAZ-TES-GLV-002
9	M8*1200 MM NO:19 THERMOCOUPLE	M.GAZ-TRL-005
10	M8*1200 THERMOELEMENT NO:18	M.GAZ-TRL-003
11	1/2-1/2 40 CM GAS FLEX	M.GAZ-TES-SPR-003
12	100*35 WHEEL	JP.M.AKS-TKR-PS-005
13	100*35 WHEEL WITH BRAKE	JP.M.AKS-TKR-PSF-006
14	BURNER LPG'Li	M.GAZ-BRL-BEK-020
15	BURNER LPG'Li	M.GAZ-BRL-BEK-021
16	NO:5 BURNER	M.GAZ-BRL-BEK-005
17	BUTTON	JP.M.AKS-DGM-EMP-025
18	3/8 50 CM GAS FLEX	M.GAZ-TES-SPR-012
19	3/8 60 CM GAS FLEX	M.GAZ-TES-SPR-011
20	1" MASHON 40 CM PIPE	M.GAZ-BRL-BRU-002

GAS TANDOORI OVEN

21	BUTTON SOCKET 8 MM	M.AKS-DGM-SKT-001
22	BUTTON BUFFER	M.AKS-DGM-EMP-016
23	BUTTON	M.AKS-DGM-EMP-024
24	HANDLE PIPEWATER (465mm)	YBR-KNX.KFR-KS-0052
25	HANDLE BODY	YTL-KNX.KFR-KS-0104
26	HANDLE FOOT	YTL-KNX.KFR-KS-0105
27	GAS FLEX Ø6 MM 120 CM	M.GAZ-TES-SPR-022
28	GAS PIPE	YBR-KNX.TDR-KS-0001
29	PIOZE LIGHTER Ø:18	M.GAZ-CKM-PIEZ-001
30	TICKET	M.AKS-OZL-MTL-006
31	Ø 60 0-350 THERMOMETER	M.GAZ-TES-TRM-003
32	CABLE 1000MM	M.GAZ-CKM-KBL-002
33	FRONT PANEL SHEET	YSC-KNX.TDR-LZ-0015
34	INJECTOR M8*0.75 Ø2.00 MM.	M.GAZ-ENJ-NG-010
35	INJECTOR M8*0.75 Ø 3.50 MM.	M.GAZ-ENJ-NG-020
36	GAS VALVE	M.GAZ-VNA-LÜX-003
37	FITTING 3/8-3/8	M.GAZ-TES-SRI-006
38	INJECTOR M8*0.75 Ø 3.00 MM.	M.GAZ-ENJ-NG-009
39	GAS TANK	M.GAZ-DPO-TDR-01
40	ENJEKTOR M8*0.75 Ø 2.50 MM.	M.GAZ-ENJ-NG-008
41	GAS VALVE	M.GAZ-VNA-ÖZR-001
42	TANDIR STONE	M.TAS-FRN-TND-001
43	NO:2 BAKALIT HANDLE	M.AKS-KLP-BKL-003