

COLD BANQUET TROLLEY

CONTENTS

A	GENERAL INFORMATION	Page 2
A1	PRODUCT DESCRIPTION	Page 3
A2	TECHNICAL INFORMATION	Page 3
A3	TRANSPORTATION	Page 4
A4	UNPACKING	Page 4
B	INSTALLATION	Page 4
C	SAFETY INSTRUCTIONS	Page 5
D	OPERATION	Page 6
E	CLEANING & MAINTENANCE	Page 7
F	TROUBLESHOOTING.....	Page 8
G	SPARE PART LIST- EXPLODING DRAWING	Page 9
H	ELECTRIC CIRCUIT SCHEMA	Page 17

A GENERAL INFORMATION

Before installing the appliance, read operation and maintenance instructions carefully. Wrong installation and part changing may damage the product or may cause injury on people. These are not in our company's responsibility to damage the appliance intentionally, negligence, detriments because of disobeying instructions and regulations, wrong connections. Unauthorized intervention to appliance invalidates the warranty.

1. This instruction manual should be kept in a safe place for future reference.
2. **Installation should be made in accordance with ordinances and security rules of that country by a qualified service personnel.**
3. This appliance has to be used by trained person.
4. Please turn off the appliance immediately in the event of malfunction or failure. The appliance should be repaired only by authorized service personnel. Please demand original spare part.

COLD BANQUET TROLLEY

A1 PRODUCT DESCRIPTION

*The Professional Cold Banquet Trolley, that provides high efficiency has been designed to be used in industrial kitchens.

Product Code	Dimensions (mm)	Weight (kg)	Packaging Dimensions (mm)
EMP.BQ1-12C	536x920x1480	80	566x964x1590
EMP.BQ1-12+12C	1115x920x1400	160	1151x964x1530
EMP.BQ2-12C	740x1036x1480	94	770x1080x1590
EMP.BQ2-12+12C	1526x1036x1400	182	1560x1080x1530

A2 TECHNICAL INFORMATION

Product Code	Operating Temperature (°C)	Capacity	Power (KW)	AMPERE (A)	Operat. Volt. (V)	Cooler Gas	Cable (mm ²)
EMP.BQ1-12C	+4 / +10 Tropikal 43	12xGn 1/1	0,15	0,8	220-230V	R-290	3x1,5
EMP.BQ1-12+12C	+4 / +10 Tropikal 43	24xGn 1/1	0,3	1,8	220-230V	R-290	3x1,5
EMP.BQ2-12C	+4 / +10 Tropikal 43	12xGn 2/1	0,15	0,8	220-230V	R-290	3x1,5
EMP.BQ2-12+12C	+4 / +10 Tropikal 43	24xGn 2/1	0,3	1,8	220-230V	R-290	3x1,5

A3 TRANSPORTATION

*This appliance can not be moved by hand from area to area. It must be moved on pallet with forklift truck.

A4 UNPACKING

*Please unpack the package according to the security codes and ordinances of current country and get rid from the pack. Parts which contacts with food are produced by stainless steel. All plastic parts are marked by material's symbol.

*Please check that all the parts of appliance had come completely and if they are damaged or not during the shipping.

B INSTALLATION

*Technician who will serve for installation and service for the appliance must be professional on this subject and must have installation and service licenses by the company.

*Please be sure that the voltage connected to appliance must be equal with the voltage which is on appliance's label.











 This appliance must be connected to an earthed outlet in accordance with safety rules and standards.

*Appliance's earthing must be connected to earthing line on panel which is nearest to electric installation.

*Connection to the main fuse and leak current fuse must be done in accordance with the current regulations.

COLD BANQUET TROLLEY

C SAFETY INSTRUCTIONS

-  *Do not use the appliance in insufficient lighted place.
-  *Do not touch the moving attachments while the appliance operates.
-  * Do not connect the device to an outlet near flammable or explosive materials.
-  *Do not operate the appliance when the machine is empty.
-  *Do not load so less or more than appliance's capacity.
-  *Do not attempt to use the appliance without suitable protective equipments.
-  *Because of any reason if there is a fire or flame flare where the appliance is used,turn off all gas valves and electric contactor switch quickly and use fire extinguisher .Never use water to extinguish the fire.
-  *All the damages because of not having earthing connection will not be on warranty.
-  *Get the necessary cautions against electric danger.
-  *Do not leave the door openen while moving the banquet trolley.It may be dangerous to move the door without control.Unplug and leave the plug on the trolley.

D OPERATION

*Control Panel;

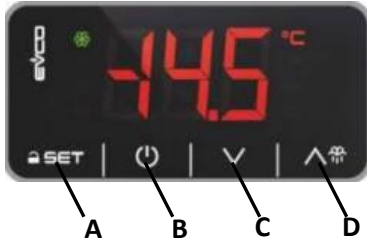

- A : SET Button
- B : ON/OFF Button
- C : Down Arrow Button
- D : Up Arrow Button

*Operating;

- Be sure that the inside of the trolley is clean and the trolley is constant to where it is before starting any process.
- Plug in the appliance.
- Switch to ON position.
- After Indicator lamps signal,inside temperature will be shown.
- You can fill the banquet trolley during cooling process..In this situation cooling time will be a little bit longer.
- After Cooling Starts ;
 - Switch to OFF position. All lamps will be off.
- Unplug it and leave the plug on the trolley.



COLD BANQUET TROLLEY

E CLEANING & MAINTENANCE

➤ **CLEANING AND MAINTENANCE AFTER EVERY USE**

- Always turn off the appliance and disconnect from the power supply before cleaning.
- Clean the inside of appliance after every use.
- Clean the inside and outside of the appliance with moist cloth and then dry.
- Do not use abrasive cleaning chemicals as these can leave harmful residues.
- Do not clean the appliance by spraying water directly, otherwise electric motor may get damaged.

➤ **PERIODIC CLEANING AND MAINTENANCE**

- Maintenance should be done by qualified person.
- Get the periodic maintenance of the appliance once in every 15 days.
- Check the wheels, electric connections, fan, control system, door and door lock once in every 6 months.
- Check the door wick in periodic time and set. Change the wicks that can not be used.



COLD BANQUET TROLLEY

F TROUBLESHOOTING

THE APPLIANCE DOESN'T OPERATE	<ol style="list-style-type: none">1. Check if the appliance is plugged in.2. Check the electrical connections and voltage.
THE APPLIANCE DOESN'T COOL	<ol style="list-style-type: none">1. Check if the thermostat control panel operates or not.2. Fan may have error. In this situation inform the service.3. If the control system has error, the appliance doesn't cool.
THE APPLIANCE STOPPED	<ol style="list-style-type: none">1. The appliance can stop due to low voltage. In this situation check the voltage.2. If there is any load on banquet trolley, the appliance may stop.
THE BRAKES CAN NOT BE APPLIED	<ol style="list-style-type: none">1. Brakes and Wheels may have error. In this situation inform the service.
DOOR IS NOT CLOSED	<ol style="list-style-type: none">1. The banquet trolley may be overloaded2. Door lock may have error.

- If cooling is not done at suitable quality
- If any function of security doesn't work
 - Do not use the appliance.

***If these problems are still going on, contact with our authorized services.**

COLD BANQUET TROLLEY

G SPARE PART LIST-EXPLODING DRAWING

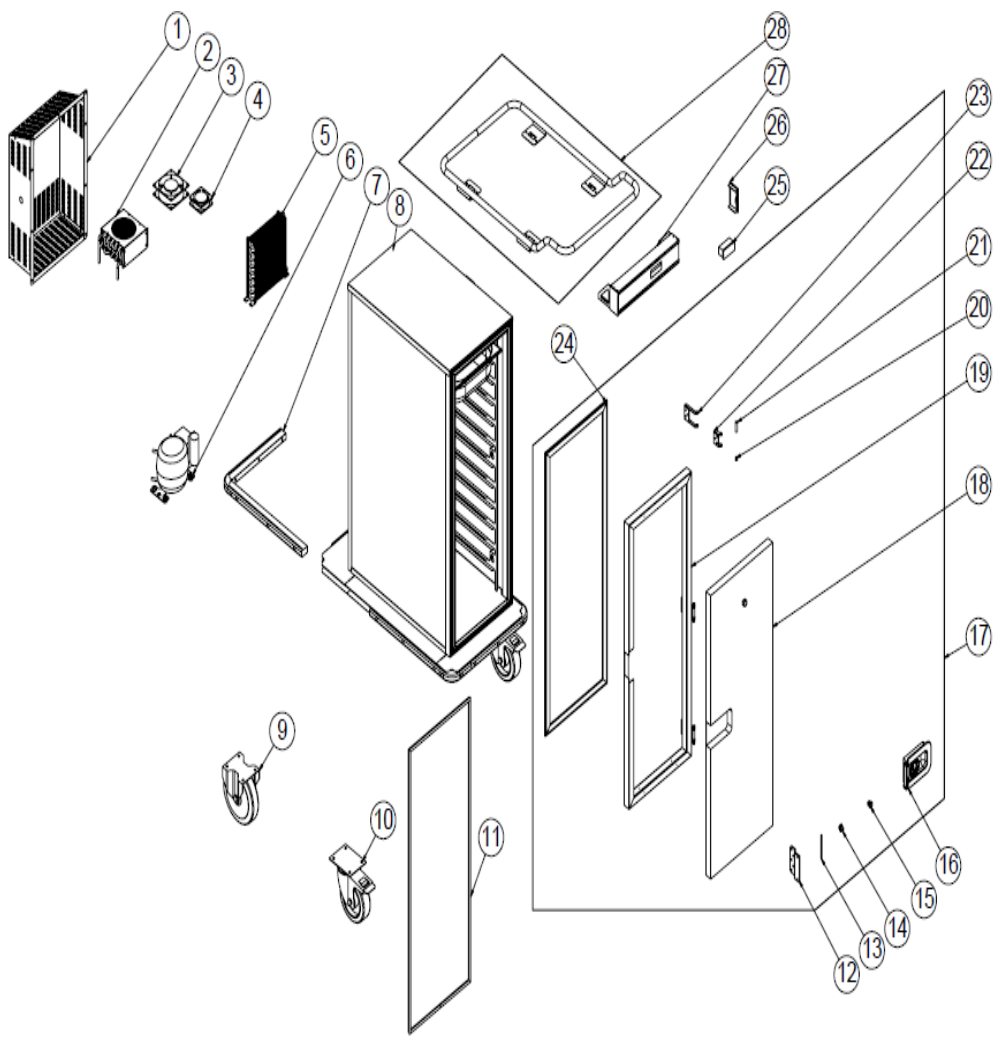

EMP.BQ1-12C

G SPARE PART LIST-EXPLODING DRAWING

PRODUCT CODE: EMP. BQ1-12C		
NO	PRODUCT NAME	P.CODE
1	SHUTTER SHEET	YSC-ERK.BQ-LZ-0222
2	MINI CONDENSER	M.SOG-KDS-038
3	FAN	ERK.M.ELK-HVL-KFN-004
4	FAN	ERK.M.ELK-HVL-KFN-010
5	MINI EVAP	M.SOG-EVP-041
6	COMPRESSOR	M.SOG-KMS-006
7	BUMPER RUBBER	M.ENJ-ERK-PLS-056
8	CHASSIS	-
9	WHEEL WITHOUT BRAKE	M.AKS-TKR-KS-013
10	WHEEL WITH BRAKE	M.AKS-TKR-KS-003
11	GASKET	M.CNT-ERK-060
12	LOCK MATTER SHEET	YSC-ERK.BQ-PN-0346
13	DOOR LOCK SHAFT	ERK.YTL-ERK.MED-KS-0063
14	KEY	ERK.M.AKS-KLT-GNL-002
15	LOCK	ERK.M.AKS-KLT-GNL-001
16	DOOR LOCK	M.ENJ-ERK-PLS-055
17	COLD COVER	ARA-ERK.BQ-0018
18	COVER PANEL 1098*414	YMH-ERK.BQ-FSM-0015
19	U PROFILE	HPR-ALM-OZL-ELO-059
20	HINGE PLASTIC	YTL-ERK.BQ-KS-0011
21	OUTER PIPE	YBR-ERK.BQ-KS-0013
22	HINGE INSIDE SHEET	YSC-ERK.BQ-LZ-0172
23	HINGE OUTER SHEET	YSC-ERK.BQ-LZ-0171
24	HEAT TRANSFER PLASTIC	M.ENJ-ERK-PLS-134
25	THERMOSTAT	ERK.M.ELK-EDM-DGT-007
26	PANEL SIDE COVER	M.MUH-071
27	PANEL SHEET	YSC-ERK.BQ-LZ-0200
28	BALCONY PIPE	ARA-ERK.BQ-0036

COLD BANQUET TROLLEY

G SPARE PART LIST-EXPLODING DRAWING

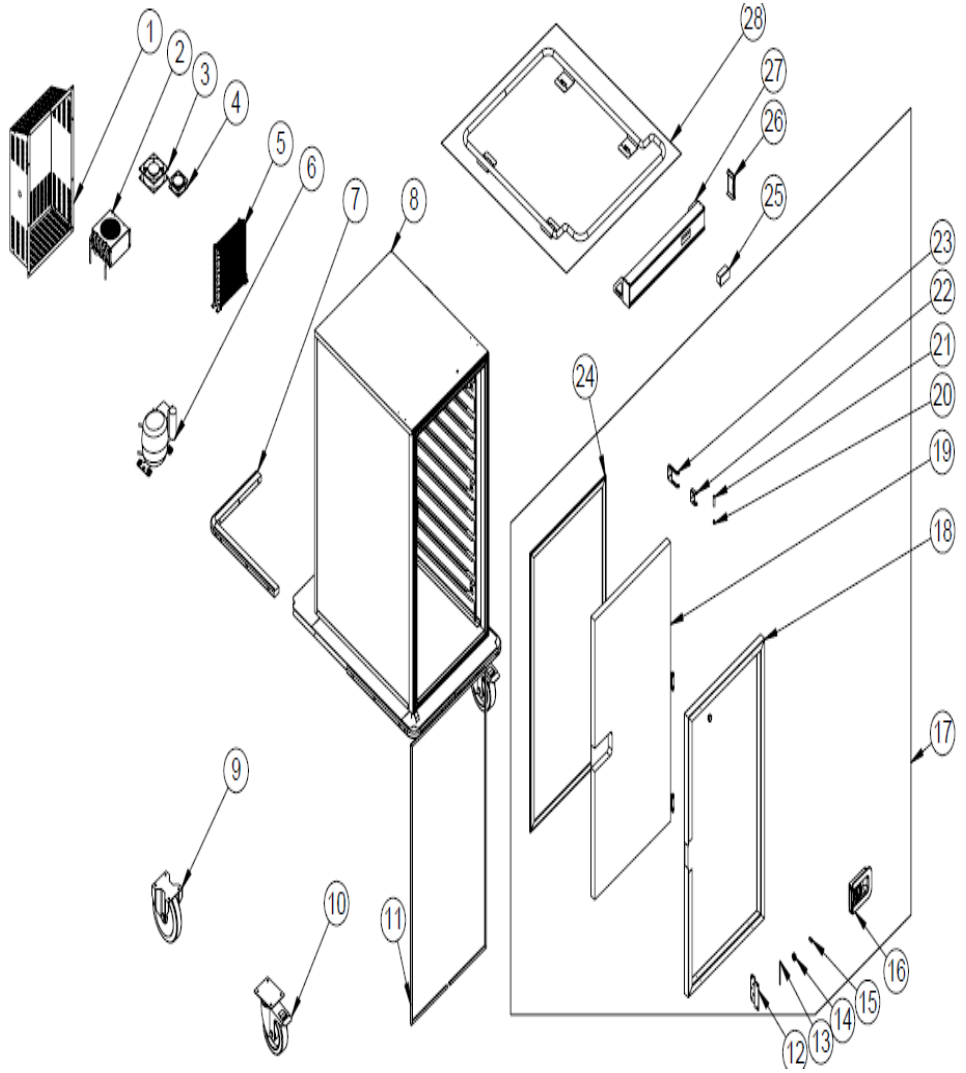

EMP.BQ2-12C

G SPARE PART LIST-EXPLODING DRAWING

PRODUCT CODE: EMP. BQ2-12C		
NO	PRODUCT NAME	P.CODE
1	SHUTTER SHEET	YSC-ERK.BQ-LZ-0222
2	MINI CONDENSER	M.SOG-KDS-038
3	FAN	ERK.M.ELK-HVL-KFN-004
4	FAN	ERK.M.ELK-HVL-KFN-010
5	MINI EVAP	M.SOG-EVP-041
6	COMPRESSOR	M.SOG-KMS-006
7	BUMPER RUBBER	M.ENJ-ERK-PLS-056
8	CHASSIS	-
9	WHEEL WITHOUT BRAKE	M.AKS-TKR-KS-013
10	WHEEL WITH BRAKE	M.AKS-TKR-KS-003
11	GASKET	M.CNT-ERK-060
12	LOCK MATTER SHEET	YSC-ERK.BQ-PN-0346
13	DOOR LOCK SHAFT	ERK.YTL-ERK.MED-KS-0063
14	KEY	ERK.M.AKS-KLT-GNL-002
15	LOCK	ERK.M.AKS-KLT-GNL-001
16	DOOR LOCK	M.ENJ-ERK-PLS-055
17	COLD COVER	ARA-ERK.BQ-0019
18	COVER PANEL 1098*619	YMH-ERK.BQ-FSM-0005
19	U PROFILE	HPR-ALM-OZL-ELO-059
20	HINGE PLASTIC	YTL-ERK.BQ-KS-0011
21	OUTER PIPE	YBR-ERK.BQ-KS-0013
22	HINGE INSIDE SHEET	YSC-ERK.BQ-LZ-0172
23	HINGE OUTER SHEET	YSC-ERK.BQ-LZ-0171
24	HEAT TRANSFER PLASTIC	M.ENJ-ERK-PLS-134
25	THERMOSTAT	ERK.M.ELK-EDM-DGT-007
26	PANEL SIDE COVER	M.MUH-071
27	PANEL SHEET	YSC-ERK.BQ-LZ-0157
28	BALCONY PIPE	ARA-ERK.BQ-0037

COLD BANQUET TROLLEY

G SPARE PART LIST-EXPLODING DRAWING

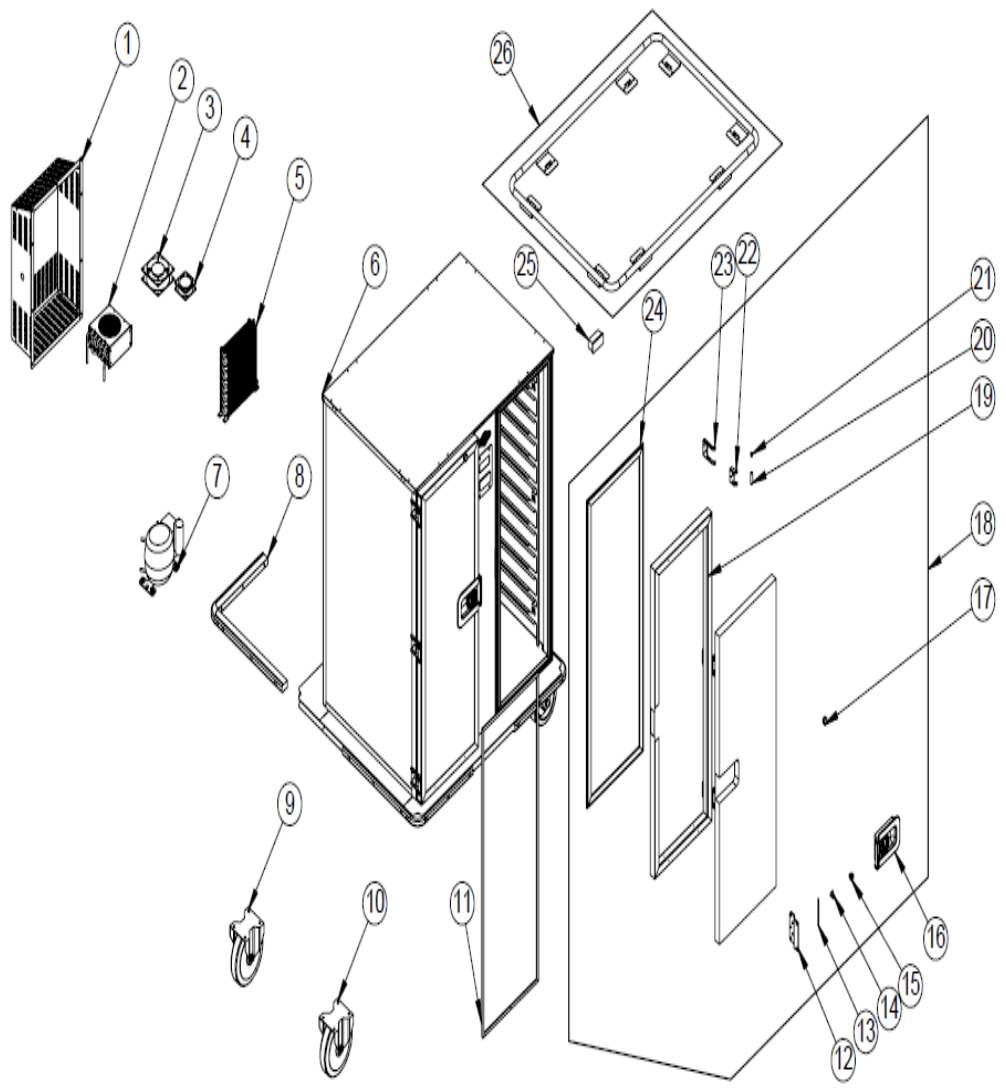

EMP.BQ1-12+12C

G SPARE PART LIST-EXPLODING DRAWING

PRODUCT CODE: EMP. BQ1-12+12C		
NO	PRODUCT NAME	P.CODE
1	SHUTTER SHEET	YSC-ERK.BQ-LZ-0222
2	MINI CONDENSER	M.SOG-KDS-038
3	FAN	M.ELK-HVL-KFN-004
4	FAN	M.ELK-HVL-KFN-010
5	MINI EVAP	M.SOG-EVP-041
6	CHASSIS	-
7	COMPRESSOR	M.SOG-KMS-006
8	BUMPER RUBBER	M.ENJ-ERK-PLS-056
9	WHEEL WITH BRAKE	M.AKS-TKR-KS-003
10	WHEEL WITHOUT BRAKE	M.AKS-TKR-KS-013
11	GASKET	M.CNT-ERK-060
12	LOCK MATTER SHEET	YSC-ERK.BQ-PN-0346
13	DOOR LOCK SHAFT	YTL-ERK.MED-KS-0063
14	KEY	M.AKS-KLT-GNL-002
15	LOCK	M.AKS-KLT-GNL-001
16	DOOR LOCK	M.ENJ-ERK-PLS-055
17	MAGNET	M.MIK-ERK-003
18	COLD COVER	ARA-ERK.BQ-0018
19	U PROFILE	HPR-ALM-OZL-ELO-059
20	OUTER PIPE	YBR-ERK.BQ-KS-0013
21	HINGE PLASTIC	YTL-ERK.BQ-KS-0011
22	HINGE INSIDE SHEET	YSC-ERK.BQ-LZ-0172
23	HINGE OUTER SHEET	YSC-ERK.BQ-LZ-0171
24	HEAT TRANSFER PLASTIC	M.ENJ-ERK-PLS-134
25	THERMOSTAT	M.ELK-EDM-DGT-007
26	BALCONY PIPE	ARA-ERK.BQ-0038

COLD BANQUET TROLLEY

G SPARE PART LIST-EXPLODING DRAWING

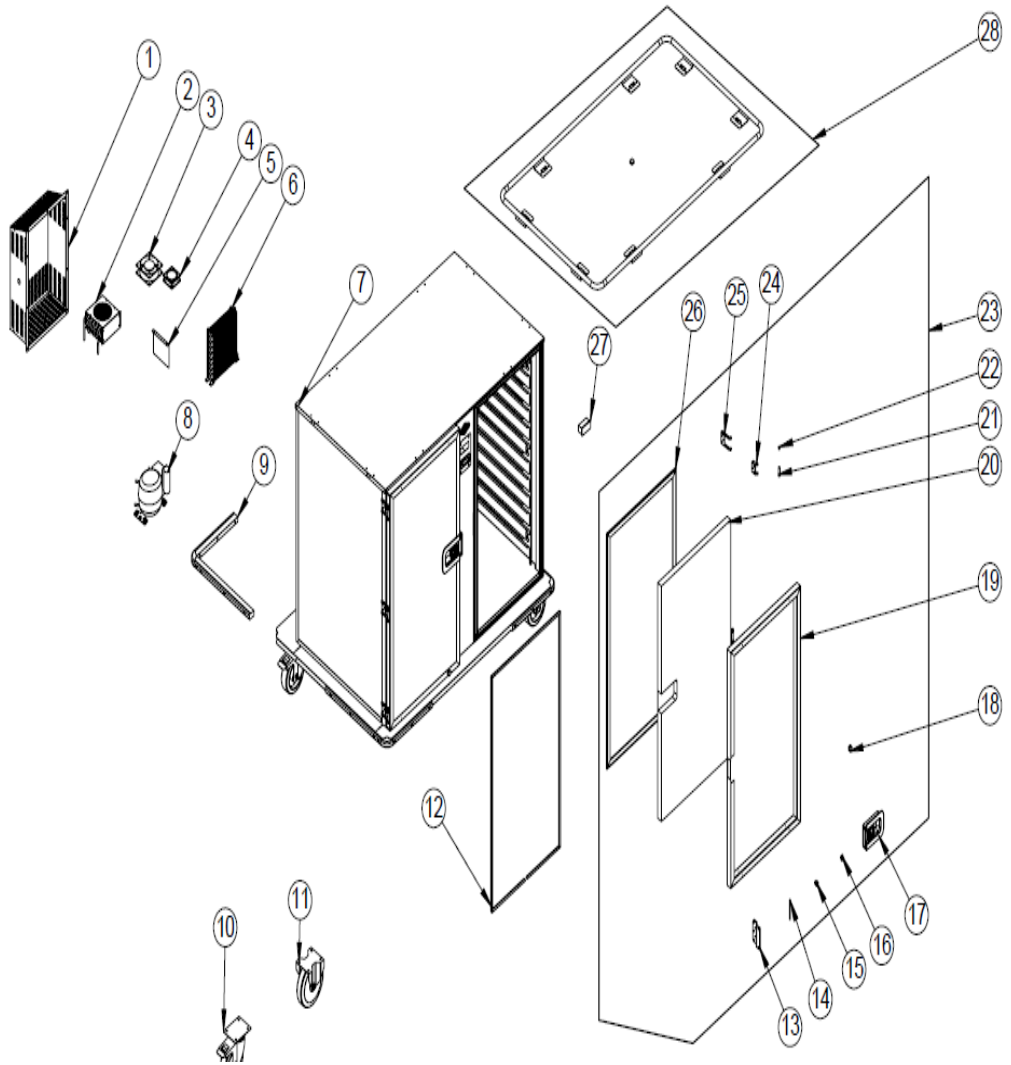

EMP.BQ2-12+12C

G SPARE PART LIST-EXPLODING DRAWING

PRODUCT CODE: EMP. BQ2-12+12C		
NO	PRODUCT NAME	P.CODE
1	SHUTTER SHEET	YSC-ERK.BQ-LZ-0222
2	MINI CONDENSER	M.SOG-KDS-038
3	FAN	ERK.M.ELK-HVL-KFN-004
4	FAN	ERK.M.ELK-HVL-KFN-010
5	CONDENSER RIGHT LEFT SHEET	YSC-ERK.BQ-LZ-0181
6	MINI EVAP	M.SOG-EVP-041
7	CHASSIS	-
8	COMPRESSOR	M.SOG-KMS-006
9	BUMPER RUBBER	M.ENJ-ERK-PLS-056
10	WHEEL WITH BRAKE	M.AKS-TKR-KS-003
11	WHEEL WITHOUT BRAKE	M.AKS-TKR-KS-013
12	GASKET	M.CNT-ERK-060
13	LOCK MATTER SHEET	YSC-ERK.BQ-PN-0346
14	DOOR LOCK SHAFT	ERK.YTL-ERK.MED-KS-0063
15	LOCK	ERK.M.AKS-KLT-GNL-001
16	KEY	ERK.M.AKS-KLT-GNL-002
17	DOOR LOCK	M.ENJ-ERK-PLS-055
18	MAGNET	M.MIK-ERK-003
19	U PROFILE	HPR-ALM-OZL-ELO-059
20	COVER PANEL 1098*619	YMH-ERK.BQ-FSM-0005
21	OUTER PIPE	YBR-ERK.BQ-KS-0013
22	HINGE PLASTIC	YTL-ERK.BQ-KS-0011
23	COLD COVER	ARA-ERK.BQ-0019
24	HINGE INSIDE SHEET	YSC-ERK.BQ-LZ-0172
25	HINGE OUTER SHEET	YSC-ERK.BQ-LZ-0171
26	HEAT TRANSFER PLASTIC	M.ENJ-ERK-PLS-134
27	THERMOSTAT	ERK.M.ELK-EDM-DGT-007
28	BALCONY PIPE	ARA-ERK.BQ-0039

COLD BANQUET TROLLEY

H ELECTRIC CIRCUIT SCHEMA

