

STRETCHING MACHINE

CONTENTS

A	GENEREAL INFORMATION.....	Page 2
A1	PRODUCT DESCRIPTION	Page 3
A2	TECHNICAL INFORMATION	Page 3
A3	TRANSPORTATION	Page 4
A4	UNPACKING	Page 4
B	INSTALLATION	Page 4
C	SAFETY INSTRUCTIONS	Page 5
D	OPERATION	Page 6
E	CLEANING & MAINTENANCE.....	Page 7
F	TROUBLESHOOTING	Page 8
G	SPARE PART LIST- EXPLODING DRAWINGS	Page 9
H	ELECTRIC CIRCUIT SCHEMA	Page 11

A GENERAL INFORMATION

Before installing the appliance, read operation and maintenance instructions carefully. Wrong installation and part changing may damage the product or may cause injury on people. These are not in our company's responsibility to damage the appliance intentionally, negligence, detriments because of disobeying instructions and regulations, wrong connections. Unauthorized intervention to appliance invalidates the warranty.

1. This instruction manual should be kept in a safe place for future reference.
2. **Installation should be made in accordance with ordinances and security rules of that country by a qualified service personnel.**
3. This appliance has to be used by trained person.
4. Please turn off the appliance immediately in the event of malfunction or failure. The appliance should be repaired only by authorized service personnel. Please demand original spare part.

STRETCHING MACHINE

A1 PRODUCT DESCRIPTION

*Professional Stretching Machine, that provides high efficiency has been designed to be used in industrial kitchens.

Product Code	Dimensions (mm)	Weight (kg)	Packaging Dimensions (mm)
EMP.SCM.01	580x435x235	8	630x490x320

A2 TECHNICAL INFORMATION

Product Code	EMP.SCM.01
Film Capacity (mm)	450
Power (Kw)	0,17
Operating Voltage (V)	220
Cable (mm ²)	3x1,5
Fuse (A)	2

A3 TRANSPORTATION

*This appliance can be moved by hand from area to area. Do not crash and drop the appliance while transporting.

A4 UNPACKING

*Please unpack the package according to the security codes and ordinances of current country and get rid from the pack. Parts which contacts with food are produced by stainless steel. All plastic parts are marked by material's symbol.

*Please check that all the parts of appliance had come completely and if they are damaged or not during the shipping.

B INSTALLATION

*Please place the product to straight and sturdy ground, please take necessary steps against possibility of overturn.

*Technician who will serve for installation and service for the appliance must be professional on this subject and must have installation and service licenses by the company.

*Connection to Electric Power Supply must be done by authorized person.

*Please be sure that the voltage connected to appliance must be equal with the voltage which is on appliance's label.











This appliance must be connected to an earthed outlet in accordance with safety rules and standards.

*Appliance's earthing must be connected to earthing line on panel which is nearest to electric installation.

*Connection to the main fuse and leak current fuse must be done in accordance with the current regulations.

STRETCHING MACHINE

C SAFETY INSTRUCTIONS

-  *Do not use the appliance in insufficient lighted place.
-  *Do not touch the moving attachments while the appliance operates.
-  *Do not install the appliance in the presence of flammable or explosive materials.
-  *Do not operate the appliance when the machine is empty.
-  *Get the necessary cautions against electric danger.
-  *Do not attempt to use the appliance without suitable protective equipments.
-  *Because of any reason if there is a fire or flame flare where the appliance is used, turn off all gas valves and electric contactor switch quickly and use fire extinguisher. Never use water to extinguish the fire.
-  *All the damages because of not having earthing connection will not be on warranty

D OPERATION

*Control Panel:

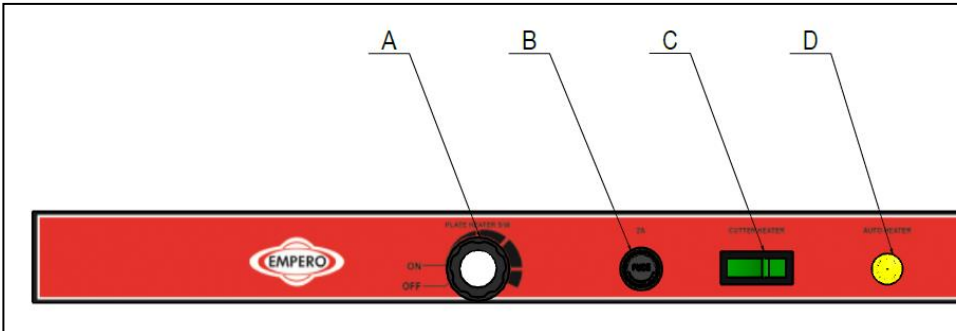

A : Plate resistance on/off / temperature setting

B : Fuse

C : Cutter resistance on/off

D : Indicator lamp

* Operating:

- Before operating the appliance,insert the Equipment (stretch film).
- Plug in the appliance.
- Turn on stand resistance and cutter resistance.See the indicator lamp is on.
- Put the product that will be stretched on to the appliance.
- Close the product by pulling roll film and then put it on to the heater plate..
- When the film is pulled to heater plate,it will be cut by heated cutter.
- When the operation is done,unplug the appliance.

STRETCHING MACHINE

E CLEANING & MAINTENANCE

➤ **CLEANING AND MAINTENANCE AFTER EVERY USE**

- Clean outer surface of appliance with hot water and then dry.
- Always turn off the appliance and disconnect from the power supply before cleaning.
- Do not use abrasive cleaning chemicals as these can leave harmful residues.
- Do not clean the appliance by spraying water directly, otherwise electrical part may get damaged.

➤ **PERIODIC CLEANING AND MAINTENANCE**

- Maintenance should be done by qualified person.
- Get the periodic maintenance of the appliance once in every 15 days.
- Check that if the power cable has error or not. If there is error at the cable, definitely do not use the appliance. Provide the cable to be changed by authorized technic service.

F TROUBLESHOOTING

THE APPLIANCE DOESN'T OPERATE	<ol style="list-style-type: none">1. Check if the appliance is plugged in.2. Check the electrical connections and voltage.
STRETCHING IS NOT SUCCESSFUL	<ol style="list-style-type: none">1. Check the film roll.If it is finished,place a new one.2. Check the resistances.3. Provide the heater and cutter plate temperatures not to be more than highest level.
THE APPLIANCE STOPPED	<ol style="list-style-type: none">1. The appliance can stop due to low voltage.In this situation check the voltage.
<ul style="list-style-type: none">• If stretching is not done at suitable quality• If any function of security doesn't work<ul style="list-style-type: none">➤ Do not use the appliance.	

***If these problems are still going on,contact with our authorized service.**

STRETCHING MACHINE

G SPARE PART LIST- EXPLODING DRAWINGS

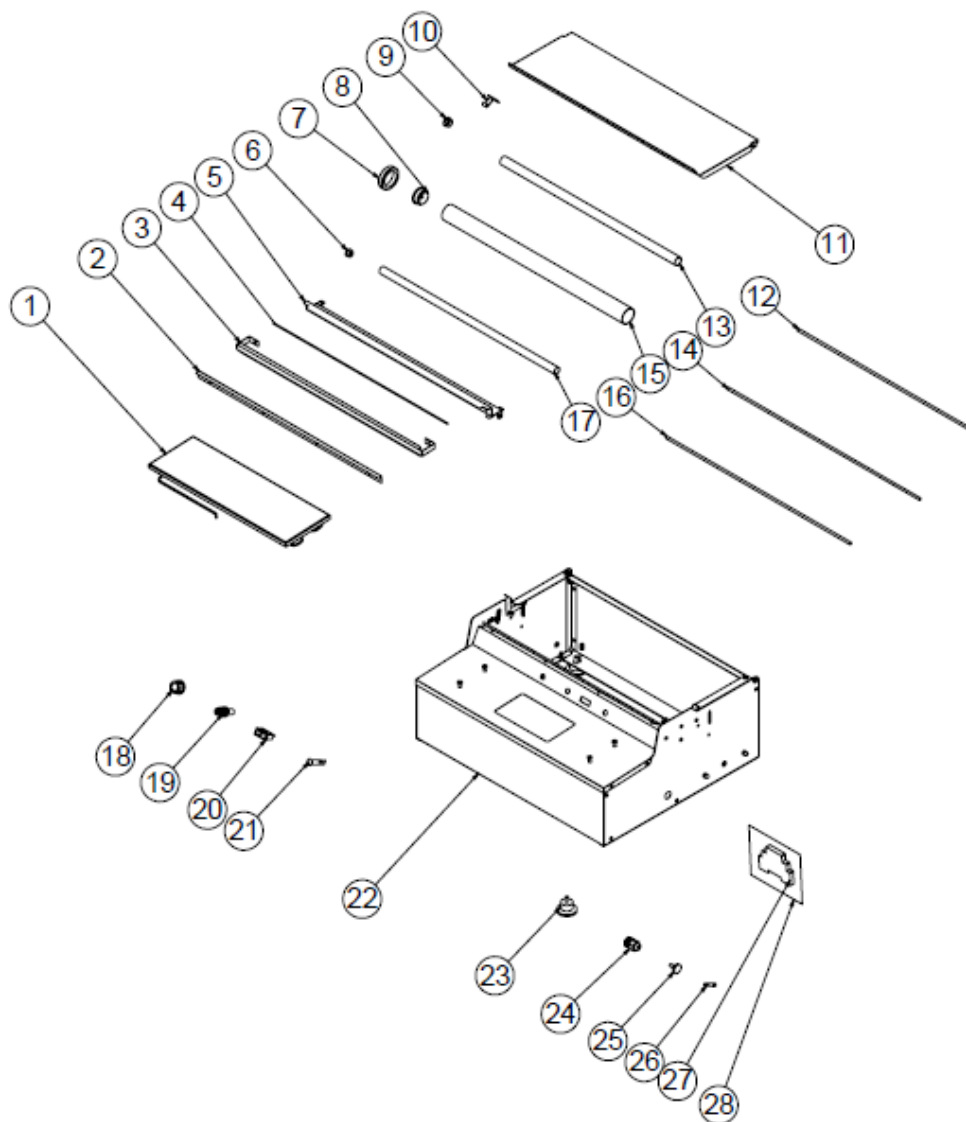

G SPARE PART LIST- EXPLODING DRAWINGS

PRODUCT CODE: EMP.SCM.01		
NO	PRODUCT NAME	P.CODE
1	TABLE RESISTANCE	M.ELK-RZS-OZL-003
2	UPPER RESISTANCE SHEET	YSC-EMP.SCM-LZ-0002
3	UPPER FRONT SHEET	YSC-EMP.SCM-LZ-0004
4	CABLE RESISTANCE	M.ELK-RZS-OZL-004
5	UPPER REAR SHEET	YSC-EMP.SCM-LZ-0003
6	SMALL ROLLER STOPPER	YTL-EMP.SCM-KS-0008
7	PLASTIC RING	YTL-EMP.SCM-KS-0006
8	LARGE ROLLER STOPPER	YTL-EMP.SCM-KS-0007
9	CENTER ROLLER STOP	YTL-EMP.SCM-KS-0009
10	ROLLER CONNECTION RIGHT SHEET	YSC-EMP.SCM-LZ-0008
11	TOP COVER SHEET	YSC-EMP.SCM-LZ-0012
12	MIDDLE ROLLER SHAFT	YTL-EMP.SCM-KS-0002
13	MIDDLE ROLLER PIPE	YBR-EMP.SCM-KS-0002
14	LARGE ROLLER SHAFT	YTL-EMP.SCM-KS-0001
15	BIG ROLL PIPE	YBR-EMP.SCM-KS-0003
16	SMALL ROLLER SHAFT	YTL-EMP.SCM-KS-0003
17	SMALL ROLLER PIPE	YBR-EMP.SCM-KS-0001
18	BUTTON	M.MUH-115
19	INSURANCE	ERS.M.MUH-045
20	GREEN LIGHT SWITCH	M.ELK-SLT-ANL-006
21	YELLOW WARNING LAMP	ERS.M.ELK-LMB-SNY-003
22	CHASSIS	-
23	FOOT	ERS.M.AKS-AYK-PLS-002
24	PG-9 CABLE FITTING	ERS.M.ELK-RKR-PLS-002
25	BOLT	M.AKS-KLP-BKL-019
26	GLASS FUSE 2A	ERS.M.ELK-SGR-010
27	CONTACTOR	ERS.M.ELK-KNT-KNT-010
28	CABLE BACKET	M.ELK-KD-SCM-001

STRETCHING MACHINE

H ELECTRIC CIRCUIT SCHEMA

